

Functional Range

EC 2 (AMF Relay)

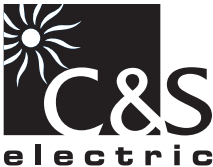

C&S Electric Limited.
(Protection & Control Division)

Contents

	Page No.
1. Introduction and Application	3
2. Features and Characteristics	3
3. Operating Modes	3-4
3.1 Automatic mode	
3.2 Remote mode	
3.3 Manual mode	
3.4 Offline mode	
3.5 Test mode	
3.6 Edit mode	
3.7 Default mode	
4. Mains supervision.	5
4.1 Parameter selection	
4.1.1 Voltage	
4.1.2 Frequency	
4.1.3 Frequency Blocking Voltage	
4.2 Circuit Breaker Supervision	
5. Generator Supervision	5-8
5.1 Parameter selection	
5.2 Battery voltage supervision	
5.3 Emergency stop	
5.4 Time circuits	
5.5 Time elements	
5.6 Periodic test	
6. Design	8-10
6.1 Connection	
6.2 Output relays	
6.3 Inputs	
6.3.1 Mains voltage connection	
6.3.2 Generator voltage connection	
6.3.3 Auxiliary supply	
6.3.4 CB feedback contacts	
6.3.5 Start/Stop signals	
6.3.6 Fault signals	
6.3.7 Internally processed fault display	
6.4 Display	
6.5 LEDs	
6.6 Front panel keypad	
6.7 Serial Communication	
7. Parameter Setting & Display	10
7.1 Mode selection	
7.2 Display Measured Parameters	
8. Terminal Details	10-12
8.1 Terminal Arrangement	
8.2 Terminal Description	
9. Getting Started	13-16
10. Functional Specification	17
11. Performance Specification	18
12. Hardware Specification	18-19

1. Introduction and Application

AMF & Engine Control Relay Type – EC2:

EC2 has been designed for the control of emergency and standby power systems. It integrates the functions of engine start/stop relay, engine and alternator supervision and annunciator. The relay has a user friendly MMI in the form of a keypad and a LCD display.

The engine start/stop relay element allows the automatic starting of relay when power fails, automatic stopping of the engine when mains return and also the control and interlocking of mains and DG Circuit Breakers. It also includes delayed supervision of oil pressure switch.

2. Features & Characteristics

- Micro controller technology.
- Wide range of auxiliary supply: 7 V to 35Vdc.
- Withstands a dip to 0V of auxiliary supply for 1 second.
- Flush mounting
- Alphanumeric LCD display with keypad for ease of operation.
- Display and supervision of three phase mains voltages for UV, OV & unbalance.
- Display and supervision of D.G voltages for UV, OV.
- Display and supervision of mains & D.G frequency.
- Continuous supervision of mains & D.G breaker status - ensures human /equipment safety.
- Internal interlock for Mains & D.G. breaker for fail safe operation.
- Remote starting and stopping facilities.
- Measuring of different mains and generator parameters.
- Ten internal fault annunciation for start failure, over speed, low battery, stop failure etc.
- Four spare terminals for connecting external fault signals.
- Display and supervision of battery voltage.
- Isolated inputs and outputs.
- Parameter setting from front panel keypad.
- Periodic test feature.
- Seven modes: Automatic, Remote, Manual, Offline, Test, Edit Parameters and Default mode.

- Over speed indication / shutdown.
- DG starting process supervision.
- Indication of CB status.
- Wide array of time circuits for start delay, stop delay, mains restoration, re-cooling etc.
- Serial Communication - RS232.
- Ignition ON input.

3. Operating Modes

EC2 operates in one of the seven modes described below.

Operating mode can be selected from the front keypad. These seven modes are:

1. Automatic
2. Remote
3. Manual
4. Offline
5. Test
6. Edit Parameters
7. Default

3.1 Automatic Mode

In the automatic mode of operation, Gen-set is started automatically, if the mains either fail or exceed operating limits, the main CB is opened and generator CB is closed.

Voltages of the three phases are monitored continuously. If voltage of any phase falls below a safe lower limit or exceeds a safe upper limit then EC2 takes following action:

During engine start delay it waits to see if mains has returned to normal. This avoids false tripping. Thereafter engine start relay (meant for operating cranking motor) is activated for a predetermined period (Start Period) and then the system waits for the engine to start and pick up threshold speed within another predetermined period (Wait Period). If the engine does not start within wait period, then another attempt is made. In this way a certain number of attempts are made. If the engine fails to start after all these attempts, then "Fail to Start" annunciation is displayed.

Delayed supervision of oil pressure is provided at the time of starting. This ensures that sufficient time is available for oil pressure to build up. If subsequently oil pressure is found to be low, then annunciation is given.

When the mains is restored, the generator CB is opened and mains CB is closed after the Mains restoration time. Then after a preset re-cooling time, the Gen-set is shut down.

The mains restoration time ensures that the mains supply voltage is stable before it is made available to consumer.

While the Gen-set is in operation, it is comprehensively protected against over-speeding, over-voltage and under-voltage conditions.

3.2 Remote Mode

In this mode, if mains fail or mains parameters go beyond operating limits, the Gen-set start only after getting a command / pulse to the remote start terminal.

Generator parameters are continuously monitored. If any parameter goes beyond the set value, generator is stopped after a set time delay.

During running of the generator, the generator is normally stopped either after getting a command / pulse to the remote stop terminal or when mains is restored. The generator CB is opened and mains CB is closed after the preset value of mains restoration time. Then the Gen-set is shut down after re-cooling time.

3.3 Manual Mode

In this mode EC2 ignores mains voltage. It only responds to **Start** and **Stop** commands from the keypad. Similarly generator and mains CBs are also operated from the keypad.

Precaution: Before giving Start command to generator, one must ensure that the generator CB is open.

Start key should be held down until the engine reaches threshold speed. The generator CB may now be switched on from keypad provided that the Mains CB is off. Stop key turns off the engine.

Precaution: While pressing stop key, the generator CB must be open. The generator is stopped without going through re-cooling phase.

The mains CB can also be activated from the keypad. Interlocking of mains and generator CBs is built into the firmware.

3.4 Off line Mode

If generator is supplying load when off mode is selected, then the generator is switched off. The entire switching off sequence is maintained. It also turns on mains CB. Mains CB can be switched off manually.

3.5 Test Mode

In this mode no-load and load test run of the Gen-set is possible. In TEST mode, the engine is automatically started and supervised and it is checked whether the generator has reached its rated voltage. Should a mains failure occur during test mode operation, the mains emergency operation is initiated automatically.

Mains CB open/close switches are active. Similarly generator CB open/close switches are also active.

3.6 Edit Parameters Mode

For a detailed description read Section 9.4. Edit parameters mode enables the user to change operating parameters. This mode can only be accessed after entering a supervisor password.

On entering Edit parameters mode relay demands the password. If the user enters correct password followed by "E" key then the line voltage is displayed which may be edited by pressing + or - keys.

The + and - keys work in a special way. If + key is pressed and released then parameter is incremented by one. If the key is held down then parameter keeps increasing by one for 10 seconds. If the key is still held down, then the parameter increases by ten. If the key is released at any point and pressed again, then once again it goes into slow mode.

Similarly the - key changes speed of decrementing, if held down.

3.7 Default Mode

In this mode the current operational mode is displayed along with different generator and mains parameters. Relay resumes this mode if unattended for 15 seconds.

4. Mains Supervision

EC2 continuously monitors three phase mains supply voltage and detects unhealthy conditions, if unhealthy conditions are detected, then it trips mains CB and initiates starting of Gen-set. Unhealthy condition shall be defined by user in Edit mode.

Unhealthy conditions are defined as follows:

- If voltage of any phase falls below a low limit or exceeds a high limit.
- If difference between voltages of any two phases exceeds a preset limit (% unbalance)
- If frequency falls below a low limit or exceeds a high limit.
- If "Single phase enable" is selected then all the phases must become unhealthy for a valid unhealthy condition.

4.1 Parameter Selection

4.1.1 Voltage

User selects lower and upper limits of line to neutral voltage in parameter setting mode. EC2 can be used for single phase / three phase systems. However the user can set under and over voltage values.

If mains voltage in any phase either exceeds the upper limit or falls below the lower limit, then it is considered an unhealthy condition. In Auto mode the relay trips mains CB if the condition prevails continuously for the user defined time delay. EC2 is also provided with mains voltage unbalance monitoring.

4.1.2 Frequency

User selects lower and upper limits of acceptable frequency. If the frequency is beyond the limits then it is considered to be an unhealthy condition and the mains CB must trip if the condition prevails longer than user defined time delay.

4.1.3 Frequency Blocking Voltage

Frequency supervision is disabled below this voltage.

4.2 Circuit Breaker Supervision

The unit is also equipped with Circuit Breaker Supervision. For supervising the healthiness of circuit breaker the feedback is to be connected at terminal 23 & 24, for Mains Circuit Breaker and for Gen. Circuit Breaker respectively.

If after issue of closing command, the check back signal of breaker is not received, the unit will indicate a fault by displaying errors on the LCD display for Mains & Generator respectively.

5. Generator Supervision

While the Gen-set supplies power, relay can also show all those abnormalities which were anticipated in mains supervision, (except voltage unbalance) there are however two added parameters: engine speed and battery voltage.

5.1 Parameter Selection

The voltage/frequency limits for the DG set can be set independently of mains settings. The setting procedures are similar to the mains parameters settings.

The over-speed is sensed through the frequency of the generating set. In case of over speed the relay trips the generator CB and proceeds to shut-down the engine without entering re-cooling phase. Voltage unbalance of DG is not checked.

5.2 Battery Voltage Supervision

EC2 relay continuously monitors battery voltage and if the voltage falls below a set value, it gives only the visual indication by flashing the LED marked "Battery Voltage" on the front plate of the relay. Indication of high battery voltage is also available with fixed settings i.e. if low battery voltage is set below 12 V high battery voltage will be automatically set as 14 V & if low battery voltage is set above 12 V, setting of high battery will be 28V.

When the battery voltage returns its operating limit, then the LED marked "Battery Voltage" returns to normal state.

5.3 Emergency Stop

The Gen-set can be stopped in the event of an emergency by shorting terminal marked "Emergency Stop" to the negative terminal of battery. In this case the re-cooling phase is bypassed.

5.4 Time Circuits

EC2 provides a user friendly MMI (Man-Machine Interface) for setting different time circuits for engine start delay, stop delay, mains restoration, re-cooling etc.

Table 1 gives the entire time settings.

5.5 Time Elements

Auto Hooter reset period

It is related to hooter operation and it can be set by the user. It starts as soon as hooter starts. If hooter is not silenced within auto-silence period, then at the expiry of this period hooter is automatically stopped.

Generator CB on Delay

Generator circuit breaker is not closed immediately after generator exceeds ignition speed. A time delay is introduced. This time delay can be set by the user. During this time EC2 checks if generator voltage is healthy.

This timer starts after generator voltage reaches safe limit.

Generator re-cooling Time

Engine is not switched off immediately after GCB: (Generator Circuit Breaker) is opened. The Gen-set needs time to cool off. If it is stopped, cooling action also stops and the heat stored in its mass starts raising its temperature.

This temperature can attain dangerous levels depending on the duty to which gen-set was subjected to before GCB was opened. Generator is allowed to run at no load for sometime, this is known as recooling time. Re-cooling time can be set by the user.

Generator Cranking Period

Engine is cranked for the duration of Generator Cranking Period and then waits for engine to start. If engine starts (generator Voltage > Ignition voltage OR Ignition On contact closes), during Generator Cranking Period then also cranking is stopped. This period can be set by the user.

Generator Cranking Wait Period

It is the time interval between two start attempts. During this period cranking is not repeated.

Mains Restoration Time

It is the time from mains recovery to closing of mains CB. This timer is started when mains recover. Mains must remain healthy during this period otherwise the timer is reset.

Generator Start Delay

It is the time between mains failure and initiation of start procedure.

Delayed Supervision Time

Oil pressure takes time to build up and hence low pressure alarm is initially on. Thus the alarm is not meaningful. We must give time for oil pressure to build up and then monitor the alarm. The process is called 'Delayed Supervision' and this time is user settable.

The timer starts after generator voltage exceeds ignition voltage.

This is also a form of delayed supervision. When GCB is closed, entire load is taken by the Gen-set. If there are loads which draw heavy starting current then generator voltage will dip as soon as GCB is closed. The dip will persist for some time. During this time generator voltage should not be monitored otherwise EC2 will decide to trip generator. The time allowed for this delayed supervision is 'Generator tripping delay'. It is user settable. This timer starts as soon as generator circuit breaker is closed.

Generator Run Hours

This timer is started as soon as GCB is closed and stopped when GCB is opened. It accumulates the time for which Gen-set runs. The time is stored in hours and goes up to 9,999 hours. The hour counter resets on exceeding 9999 hours.

Generator Off Delay

This timer is started as soon as either generator unhealthy condition is detected or mains restoration time is over and generator CB is turned off when the set time elapses. This time is set to Generator Off delay.

Description	Displayed As	Range	Steps	Default Setting	
Mains Rated Voltage	MAINS RATED VOLT	0-999	1V	230V	
Mains Under Voltage	MAINS UNDER VOLT	0-999	1V	180V	
Mains Over Voltage	MAINS OVER VOLT	0-999	1V	250V	
Mains Rated Frequency	MAINS RATED FREQ	40-99.9	0.1 Hz	50Hz	
Mains Under Frequency	MAINS UNDER FREQ	40-99.9	0.1 Hz	47.5Hz	
Mains Over Frequency	MAINS OVER FREQ	40-99.9	0.1 Hz	52.5Hz	
Generator Rated Voltage*	GEN RATED VOLT	0-999	1V	230V	
Generator Under Voltage	GEN UNDER VOLT	0-999	1V	180V	
Generator Over Voltage	GEN OVER VOLT	0-999	1V	250V	
Generator Rated Frequency	GEN RATED FREQ	40-99.9	0.1 Hz	50.0Hz	
Generator Under Frequency	GEN UNDER FREQ	40-99.9	0.1 Hz	47.5Hz	
Generator Over Frequency	GEN OVER FREQ	40-99.9	0.1 Hz	52.5Hz	
Mains Frequency Blocking Voltage	M_FREQ_BLK_VOLT	0-999	1V	100V	
Generator Frequency Blocking Volt.	G_FREQ_BLK_VOLT	0-999	1V	100V	
Over Speed	OVER SPEED	40-99.9	0.1 Hz	55.0 Hz	
Ignition Voltage	IGNITION VOLT	0-999	1V	60V	
Generator CB on Delay	GEN CB ON DELAY	0-999	1 Sec.	3 Sec	
Generator Re-cooling Time	GEN RECOOL TIME	0-999	1 Sec.	180 Sec	
Generator Cranking Wait Period	GEN CK WAIT TIME	0-999	1 Sec.	10 Sec	
Mains Restoration Time	MAIN RESTOR TIME	0-999	1 Sec.	30 Sec	
Generator Start Delay	GEN START DELAY	V1.5	0-999	1 Sec.	3 Sec.
		V1.6	0-999	1 Min.	3 Min.
		V1.71	0-999	1 Sec.	3 Sec
		V1.10	0-9999	1 Sec.	3 Sec.
Generator Off Delay	GEN OFF DELAY	0-999	1 Sec.	3 Sec	
Delayed Supervision time	DELAY SUPER TIME	0-999	1 Sec.	10 Sec	
Generator Tripping Delay	GEN TRIP DELAY	0-999	1 Sec.	5 Sec	
Single Phase Enable	1 PHASE ENABLE	0-1	-	0	
Auto Hooter Reset Period	HOOTER RST TIME	0-999	1 Sec.	30 Sec	
Mains Unbalance Voltage	M UNBALANCE VOLT	1-999	1%	25%	
Number of Generator Cranking	NO. OF GEN CRANK	1-9	1	3	
Generator Cranking Period	GEN CRANK PERIOD	0-999	1 Sec.	1 Sec	
Stopper Time	STOPPER TIME	1-999	1 Sec.	10 Sec.	
Battery Low Indication	BAT LOW INDICATN	6-999	1V	10.5V	
Periodic Test Delay	PERIOD TEST TIME	0-999	1 Hour	0 Hour	
Duration of Test Mode	TEST MODE DURATN	0-99	1 Min.	5 Min.	
MCB Close Timer**	MCB CLOSE TIMER	0-999	1 Sec.	15 Sec.	

Table 1: Different parameter settings in edit mode

* This parameter is not available in Version - 1.71

** This parameter is available in Version - 1.71 only

Stopper Time

A thirty second timer starts as soon as stopper is operated. Stopper timer is started if

1. Generator voltage falls below ignition voltage or
2. Thirty second timer expires. In any case stopper remains operated until stopper timer runs out.

5.6 Periodic Test

In periodic test function the unit will automatically change its mode of operation from Auto to Test mode after a preset time (Periodic Test Delay) & remains in test mode for a set duration (Duration of Test Mode). After the elapse of set duration of test mode the unit returns to auto mode. Periodic test is permitted only in Auto mode. If "Periodic Test Delay" or "Duration of Test Mode" is set to zero then this mode is disabled.

6. Design

6.1 Connection

The connection diagram for the AMF relay EC2 is shown in the Fig.2

6.2 Output relays

EC2 has six output relays. All functions and terminals of these output relays are described in the Table 2 shown below.

Relay No.	Description	Terminal NO.
1	Hooter/Alarm	9,10
2	Mains CB release	11,12
3	Generator CB release	13,14
4	Generator starter	15,16
5	Fuel valve open	17,18
6	Generator stopper	19,20

Table 2: Output relay description

6.3 Inputs

6.3.1 Mains Voltage connection

Mains supply voltage connection to the relay EC2 is shown in the Fig 2. The mains line voltage supply is connected to terminal number 2, 3 & 4 with neutral at terminal 1 of the EC2 relay. For single phase operation make connection across any phase and neutral.

6.3.2 Generator voltage connection

Gen. supply voltage connection to the relay EC2 is shown in Fig2. Generator line voltage supply is connected to terminal numbers 5 and gen. neutral at terminal no. 6 of relay.

6.3.3 Auxiliary supply

The relay EC2 has SMPS auxiliary supply, which has the DC supply voltage range 7 - 35 V DC. This voltage supply is connected positive (+ve) to the terminal No. 21 and negative (-ve) to the terminal No. 22.

6.3.4 CB Feedback Contacts

The relay EC2 has two CB feedback contacts one for mains CB and one for generator CB which are connected to the terminals 23 and 24 respectively.

6.3.5 Start/Stop signals

The relay EC2 has three start/stop input signals. One for emergency generator stop signal which is connected to the terminal number 26 of the relay. The other two signals are used for remote starting and stopping of generator in "Remote Mode" only. These signals are connected to the terminal numbers 27 and 25 respectively.

6.3.6 Fault signals

There are four external input fault signals provided in relay EC2. These faults can be programmed in the Setup/Configuration mode as per requirement. Details of these faults are listed in table no. 3 and 4.

Description	Type	Default Setting
Fault No.1	0,1,2,3,4	0
Fault No.2	0,1,2,3,4	0
Fault No.3	0,1,2,3,4	0
Fault No.4	0,1,2,3,4	0

Table 3: Fault setting

0	Disabled
1	Display only.
2	Display with Hooter/ Alarm.
3	Display, Hooter/Alarm with normal shut down of generating set.
4	Display, Hooter/Alarm with emergency shut down of generating set

Table 4: Fault priority level:

Annunciation

External fault Inputs	Displayed As
Over current	OVER CURRENT
Short circuit current	SHORT CKT CURRNT
Low lube oil pressure	LOW LUBE OIL PRE
High cooling water temperature.	HIGH COOL TEMP
Low fuel level.	LOW FUEL LEVEL
Under excitation	UNDER EXCITATION
Over excitation	OVER EXCITATION
Earth fault	EARTH FAULT
Stator fault	STATOR FAULT
Rotor fault	ROTOR FAULT
Reverse power	REVERSE POWER
V – belt loose	V-BELT LOOSE

6.3.7 Internally processed fault display

Different internally processed fault displays in the relay are:

1	Mains CB open fail
2	Mains CB close fail
3	Generator voltage unhealthy
4	Generator fails to start
5	Generator fails to stop
6	Generator CB open fail
7	Generator CB close fail
8	Fail to build
9	Generator over speed
10	Generator Emergency Stop

Table 5: Internally Processed fault display

6.4 Display

The AMF relay EC2 is equipped with an alpha numeric LCD display to provide the Man-Machine Interface (MMI). The mains / generator measuring parameters may be checked when required. The relay also displays abnormalities of mains/generator parameters, CBs etc.

6.5 LEDs

There are eight LED indication provided in the front panel of the relay EC2, and all the eight LEDs are red LEDs and are accompanied with a legend. The functions of these LEDs are described in the Table 6.

LEDs	OFF	STEADY	FLASHING
Voltage	Healthy	X	Unhealthy
Frequency	Healthy	X	Unhealthy
Mains CB	CB OFF	CB ON	X
Gen CB	CB OFF	CB ON	X
Battery Voltage	Voltage Healthy	X	Voltage Unhealthy
Low Oil Pressure	No Fault	X	Fault Occurred
Engine TempHigh	No Fault	X	Fault Occurred
Low Level Fuel	No Fault	X	Fault Occurred

Table 6: Function/Indication of LEDs

6.6 Front Panel Keypad

The front panel keypad consists of eleven keys which are arranged into two groups. These are

- Command keys
- Edit keys

The command keys are six in number and are marked as **Gen Start**, **Gen Stop**, **Gen CB Open**, **Gen CB Close**, **Mains CB Open** and **Mains CB Close**.

There are five Edit Keys marked as **Enter**, "**↔**", "**←**", **+** and **-** Edit keys serve following functions

"↔" Key [Select Forward]

This key selects the mode of operation. These are:

Default mode, Edit parameter mode, View parameter mode, Manual mode, Selection mode Password mode and Load mode. The relay enters the specified mode only after the **Enter** key is pressed. The different mode description is given in the Table 1.

"←" Key [Select Backward]

This is a multifunctional key. It performs following functions.

- When there is no fault, it is used for backscrolling.
- In the presence of a fault it is used as 'Silence'key to silence hooter.
- In the presence of a fault, the fault can be reset by holding down this key for 4 seconds. The display will come back on the default screen as the acknowledgement of reset.

“+” -

This key increments the value of the parameter being displayed in Edit Para mode. This key is also used to toggle between the mains and the generator parameter display screens. This key is also used to enter and change the password.

“-” -

This key decrements the value of parameters being displayed in EDIT mode. This key is also used to toggle between the mains and the generator parameter display screens. This key is also used to enter and change the password.

“Enter”

This key activates selected mode in mode selection process.

“GEN START”

This key is active in Manual mode. It starts the generator.

“GEN STOP”

This key is active in Manual mode only. It stops the generator.

“GEN CB OPEN”

This key is active in Manual and Test modes. It opens generator CB.

“GEN CB CLOSE”

This key is active in Manual and Test modes. It closes generator CB.

“MAIN CB OPEN”

This key is active in Manual, Test and Offline modes. It opens mains CB.

“MAINS CB CLOSE”

This key is active in Manual, Test and Offline modes. It closes mains CB.

6.7 Serial Communication

EC2 is equipped with RS232 communication which allows interfacing the relay with Personal Computer. All the relay settings and controls are accessible via PC. A null modem cable is required for normal communication while a modem cable is required for communication through modem.

7. Parameter Setting/Display Procedure:**7.1 Mode selection**

To scroll through various modes press “ → ” key. We can select parameters by pressing Enter key.

7.2 Display Measured Parameters

To scroll through parameters, press “+” key. Refer Getting Started for details.

8. Terminal Details**8.1 Terminal arrangement**

The terminal arrangement of the AMF relay EC2 is shown in the Fig. 1.

8.2 Terminal description

The terminal description of AMF relay EC2 is:

Terminal No	Description
1	Mains Neutral
2,3,4	Mains Voltage*
5	Generator Voltage
6	Generator Neutral
7	Not Connected
8	Earth
9,10 (NO)	Hooter/ Alarm contact
11,12 (NC)	Mains CB release contact
13,14 (NO)	Generator CB release contact
15,16 (NO)	Generator start contact
17,18 (NO)	Fuel valve on contact
19,20 (NO)	Generator stop contact
21	Auxiliary supply (+ve)
22	Auxiliary supply (-ve)
23	Mains CB feedback
24	Generator CB feedback
25	Generator remote stop
26	Generator emergency stop
27	Generator remote start
28	Ignition ON Input
29	Fault signal 1
30	Fault signal 2
31	Fault signal 3
32	Fault signal 4

Note: * is for the single phase operation. Use any phase to neutral connection

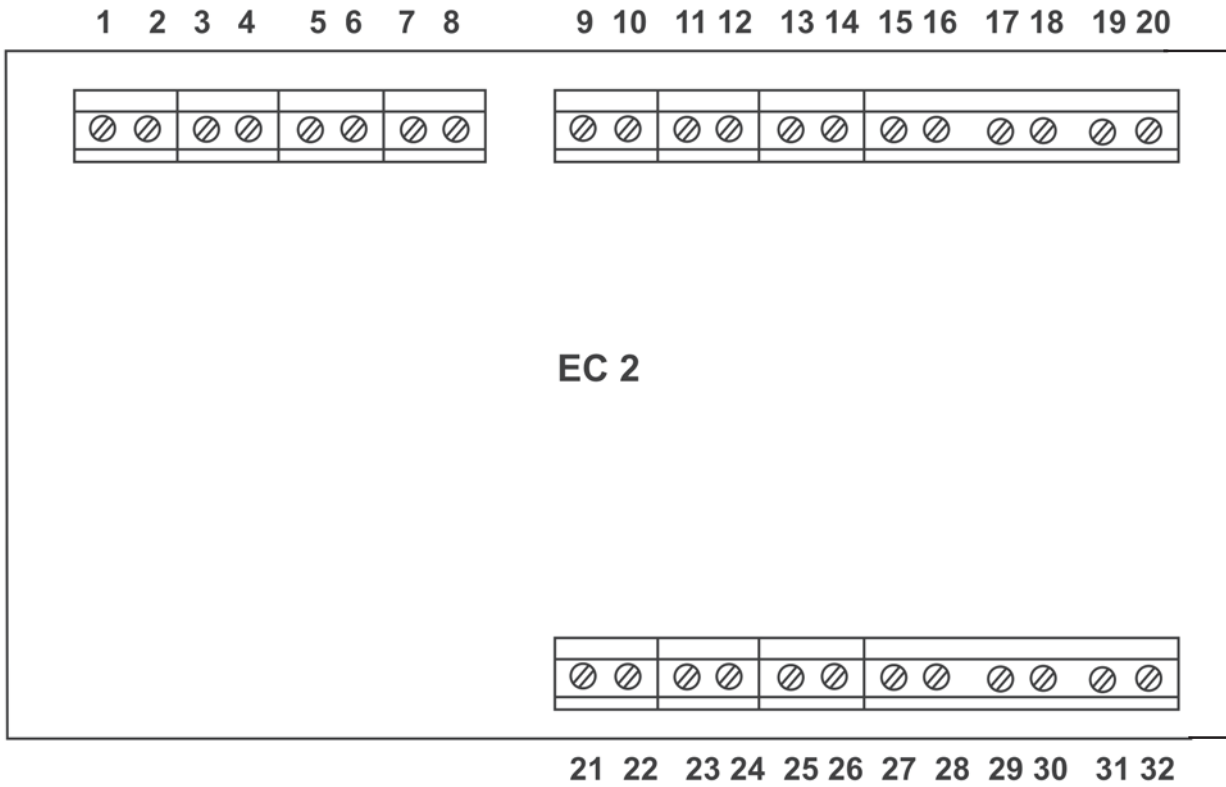



Fig. 1: Terminal Arrangement Viewed from Rear

WARNING
PLEASE PROVIDE APPROPRIATE FUSES
ON CIRCUITS WIRED TO TERMINALS
10, 12, 14, 16, 18 AND 20

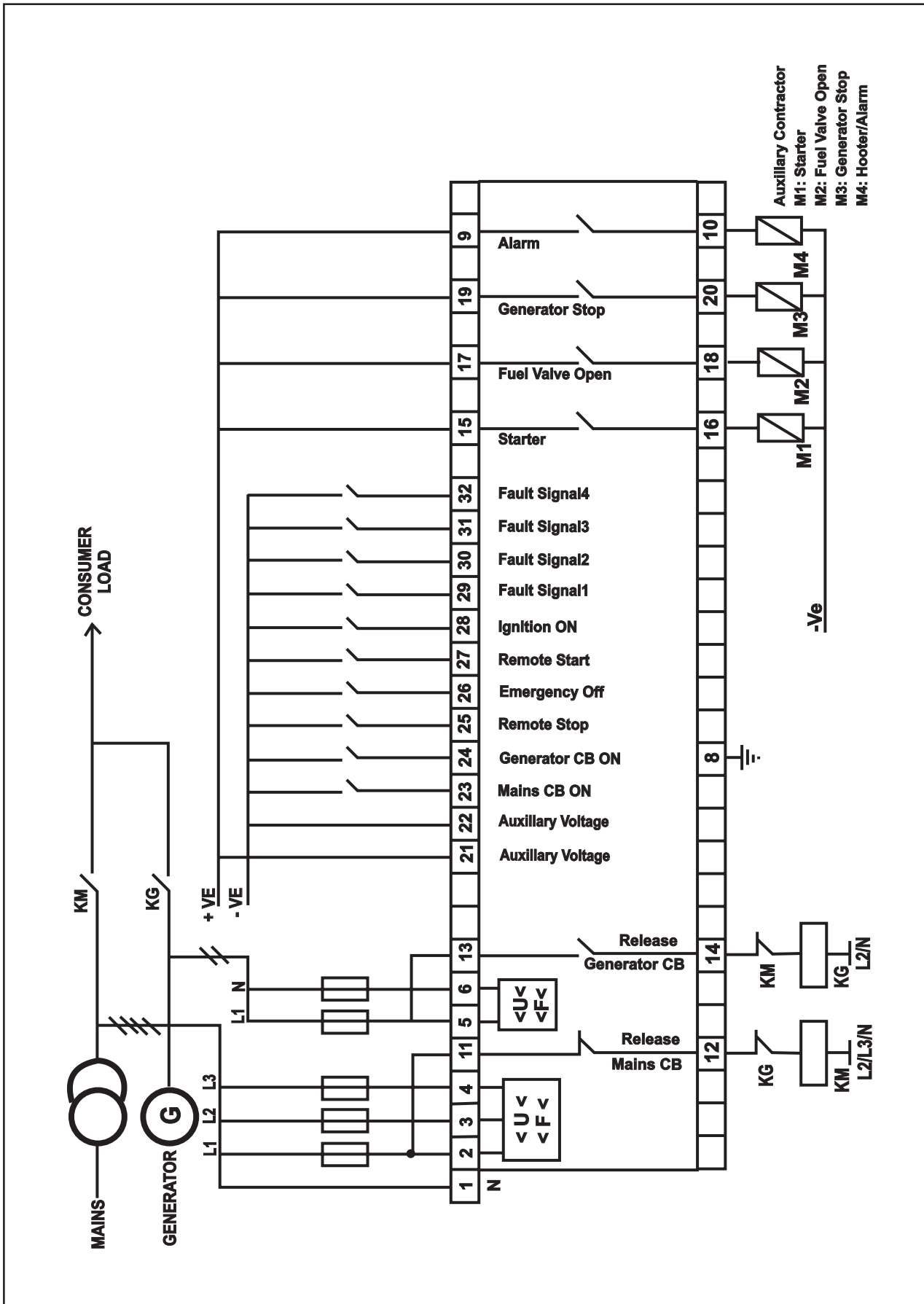
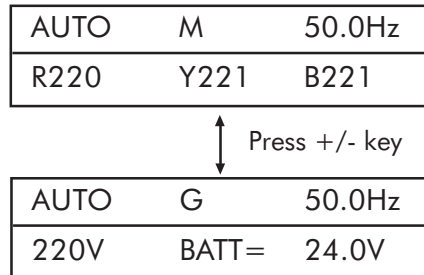

Fig. 2 : Connection Diagram for EC2 Relay

9 Getting Started

9.1 EC2 displays various parameters in "Default Mode"

- 9.1.1 The current operational mode is displayed in the Mains screen indicated by the "M" in the centre of the first line, followed by the mains frequency and the three line voltages in the second line of the LCD display.
- 9.1.2 Similarly the current operational mode is displayed in the Generator screen indicated by the "G" in the centre of the first line, followed by the generator frequency and the battery voltage in the second line of the LCD display.
- 9.1.3 Generator and mains screen can be viewed alternatively by pressing "+/-" keys on keypad.



9.2 EC2 displays faults along with generator parameters in "Default Mode"

- 9.2.1 If any external or internal fault comes, then EC2 comes into fault displaying mode. In this mode default generator and fault screen toggles.
- 9.2.2 In fault screen, one fault is displayed in the first line and an instruction to reset the fault (by pressing "←" for four seconds) is displayed in second line.
- 9.2.3 If more than one faults are present they can be viewed by pressing "E" when fault has been displayed followed by "+/-" keys.
- 9.2.4 Mains and generator screens can be viewed by pressing "E" when generator screen has been displayed followed by "+/-" keys.

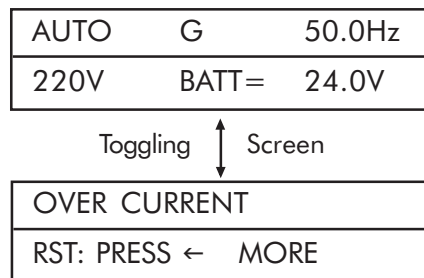

- 9.3 EC2 enters in the menu selection by pressing "→" (Forward Select) & "←" (Backward Select)
- 9.3.1 Scrolling through different modes can be done with "→" (For. Select) & "←" (Back Select) keys.
- 9.3.2 By pressing "E" (Enter) we can go in to the selected mode.
- 9.3.3 Default mode is meant for returning to the default screen view.
- 9.3.4 Edit parameter mode is for editing parameter. It is protected by service password.
- 9.3.5 View parameter mode is only to view parameters. Parameters can't be changed.
- 9.3.6 MANUAL DIAG MODE is for viewing the diagnostic parameters: Engine Run Hours, MCB trip count and GCB trip count
- 9.3.7 Selection mode is for selecting the operational mode.
- 9.3.8 Password mode is to change the service password. It requires the service password while changing.

9.3.9 Load default mode is for loading the default parameters, default service password and resetting of engine runhours. It is protected by the master password.

9.3.10 EC2 will return to the default screen display mode if left unattended for more than 16 seconds at any stage.

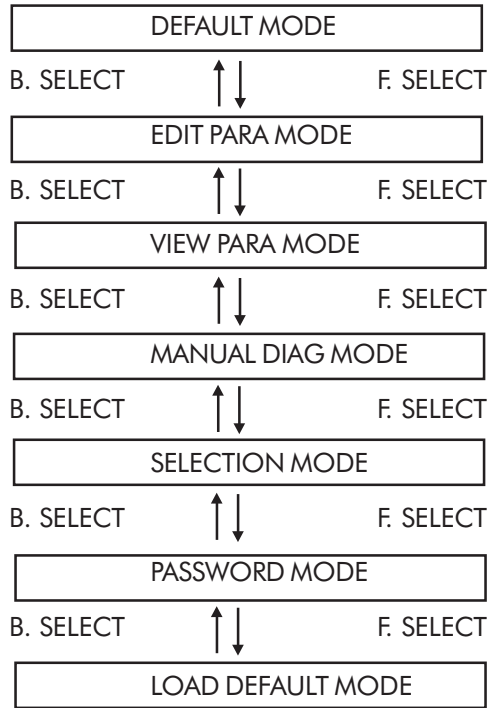

9.4 Edit Para Mode:

- 9.4.1 Enter the edit para menu by entering correct service password and then pressing "E". Scrolling through different editable parameters can be done with "→" & "←" keys. By using the "+" & "-" key parameters values can be increased or decreased.
- 9.4.2 External faults legend and level can be edited by pressing "+" & "-" key when fault parameters appear. Type (Level) of the fault can be Inc/Dec when cursor points the Type and legend can be changed when it points legend.
- 9.4.3 Further presses of "→" will roll over the parameter list from the start.
- 9.4.4 By pressing "E", EC2 will ask whether to save the edited parameters which can be selected or not by "+" & "-" keys. Pressing "E" on "Yes" will save the parameter set and will automatically exit to the default mode.
- 9.4.5 The current mode has been written at the end of second line.

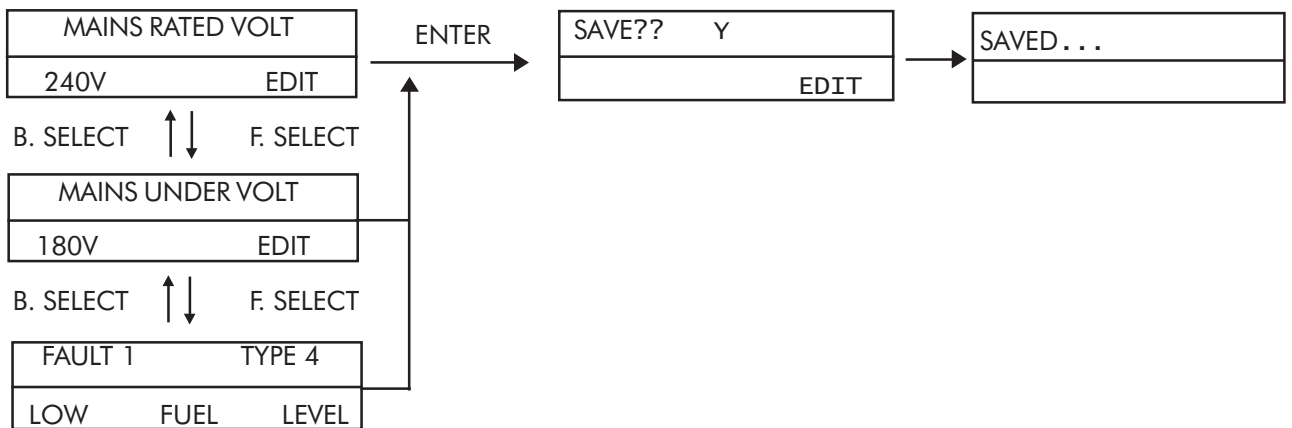

9.5 View Para Mode:

- 9.5.1 Enter the view para menu by pressing "E". Scrolling through different non-editable parameters can be done with "→" & "←" keys.
- 9.5.2 Further presses of "→" will roll over the parameter list from the start.
- 9.5.3 By pressing "E", EC2 will revert to the default mode.
- 9.5.4 The current mode has been written at the end of second line

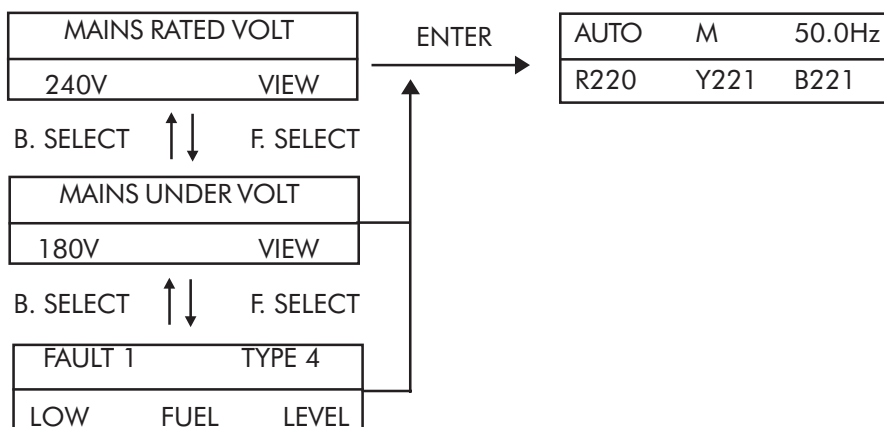

9.6 Manual Diag Mode:

- 9.6.1 Enter the manual diagnostic menu by pressing "E". Scrolling through different parameters can be done with "→" & "←" keys.
- 9.6.2 Further presses of "→" will roll over the parameter list from the start.
- 9.6.3 By pressing "E", EC2 will revert to the default mode.
- 9.6.4 The current mode has been written at the end of second line.

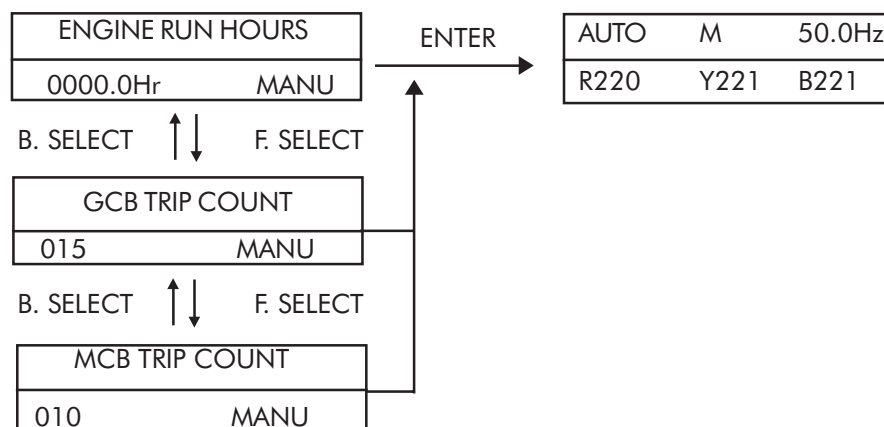

9.7 Selection Mode:

- 9.7.1 Enter the operational mode selection menu by pressing "E". Scrolling through different modes can be done with "→" & "←" keys.
- 9.7.2 Further presses of "→" will roll over the parameter list from the start.
- 9.7.3 Current operational mode can be identified as mode with already written "Selected".
- 9.7.4 By pressing "E", EC2 current selection will be selected and will return to the default displays.
- 9.7.5 Current mode has been written at end of second line

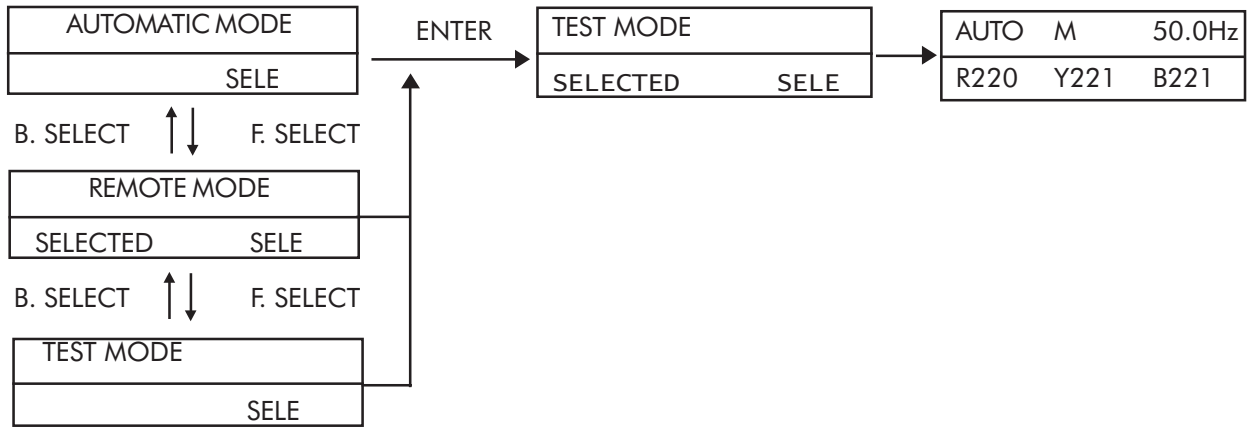

9.8 Password Modes:

- 9.8.1 Enter the change password menu by pressing enter to the "Chng Super Pass".
- 9.8.2 Enter the old supervisor password which if found invalid will popup the "Invalid Password" error and will return to the default mode.
- 9.8.3 Change the new supervisor password and confirm it.
- 9.8.4 The current mode has been written at the end of second line.

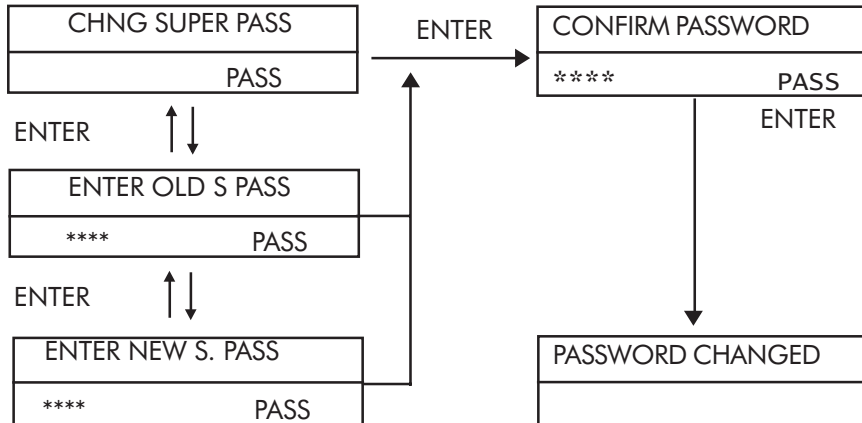

9.9 Load Default Mode

- 9.9.1 Enter the load default menu by entering correct master password and then pressing "E". Scrolling through different parameters can be done with "→"& "←" keys.
- 9.9.2 Further presses of "→" will roll over the parameter list from the start.
- 9.9.3 By pressing "E", EC2 will load default parameter or service password or will reset the engine run hours.
- 9.9.4 The current mode has been written at the end of second line.

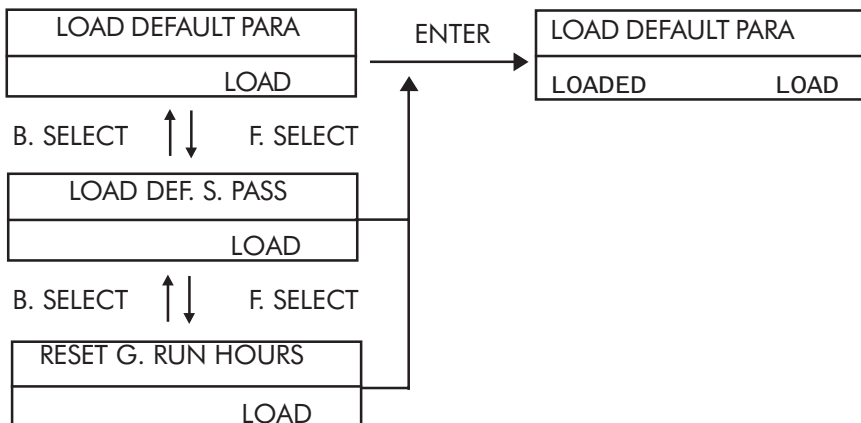

10. Functional Specifications

S.No.	Parameter	Specification			
1	Selection mode	Auto with Periodic Test Enabled/Disabled			
2		Manual			
3		Off			
4		Remote			
5		Test			
6	Functions	View actual values (Default Mode)	Mains voltages: Phase voltages (R Y B)		
7			Mains Frequency		
8			Generator Voltage – phase voltage		
9			Generator Frequency		
10			Battery Voltage		
11		View Set Parameters (View Para Mode)	Voltage rated, upper and lower limits for mains and Generator	Frequency rated, upper and lower limits for mains and generator	
12				Unbalance limit for mains voltage	
13				Enable mains operation on single phase	
14				Voltage limit below which frequency of mains/generator is not read	
15				Battery voltage Low value	
16				Ignition voltage	
17				Over speed limit	
18				Number of cranking attempts	
19				Generator start delay	
20				Generator cranking period	
21				Stopper delay	
22				Cranking wait period	
23				Re-cooling Time	
24				Generator CB on delay	
25				Generator Tripping delay	
26				Delayed supervision	
27				Generator off delay	
28				Mains restoration time	
29				Periodic test delay	
30				Periodic test duration	
31				Hooter Reset Time	
32				Edit Parameters (Edit Para Mode)	Set all above parameters. This mode is protected by Supervisor Password.
33				View values (Manual/Diagnostic Mode)	Engine Run Hours
					GCB Trip Count
					MCB Trip Count
34		Change Password (Password Mode)	Supervisor password can be modified.		
35	Load Default Mode	This mode loads default parameters, supervisor password and resets diagnostics parameter. It is protected by Master Password.			

36		Select functional mode (Mode Select Mode)	Automatic mode	
			Remote mode	
			Manual mode	
			Offline mode	
			Test mode	
37		Supervision	Three line voltages of mains -voltage band -unbalance limit	
38				One line voltage of generator -voltage band
39				Frequency of mains -frequency band
40				Frequency of generator -frequency band
41				Battery voltage -voltage band

11. Performance Specifications

S.No	Parameter	Specification
1	Aux Supply	7.0 – 35.0 V DC:
2	Aux supply InterruptionTime	1 second Sustains battery dip down to zero volts for one second without requiring external capacitor bank.
3	Aux supply burden	<3 W @24 V DC
4	External cap. bank	Not Required
5	Generator voltage	50 to 300V AC (Ph-N)
6	Mains voltage	50 to 300 V AC (Ph-N)
7	Rated frequency	50 / 60 Hz
8	Voltage measuring tolerance	+/- 1%
9	Freq. measuring tolerance	+/- 0.5%
10	VBatt Supervision	9.0 – 35.0 V
11	Tolerance of V _{Batt} measurement	+/- 1%

12. Hardware Specifications

S.No.	Parameter	Specification
1	Display	16 characters/row x 2 rows LCD display with built in controller
2	Annunciation using LEDs	Voltage
3		Frequency
4		Mains CB
5		Gen CB
6		Battery Voltage
7		Low Oil Pressure
8		Engine Temp. High
9		Low Fuel Level
10		Key pad 11 Keys

11		2 Control Keys 6 Keys	Gen Start, Gen Stop, Open Mains CB, Close Mains CB, Open DG CB, Close DG CB
12	External faults - 4	Opto-isolated I/Ps	
13	Controls – 3	Opto-isolated I/Ps	Emergency Stop
14			Remote Stop
15			Remote Start
16	Feed Back – 3	Opto-isolated I/Ps	MCB check back
17			GCB check back
18			Ignition on
19	Relay – 6 nos.	N/O Contacts	Starter Motor
20	O/P Contact rating (All relays) – 250 V AC, 4A resistive		Fuel Injection
21			Decompression Coil (Stopper)
22			Generator CB
23			Hooter
24			N/C Contacts
25		Communication	Serial full duplex RS232 Modem enabled (Bi-directional) Windows based Proprietary Software
26	Serial connector	9-pin subminiature D-connector	
27	Storage temp.	- 40°C - +75°C	
28	Operating Temp	- 20°C - +70°C	
29	Connecting terminals	max 2.5 mm ² Recommended 2.5 mm ² conductor	
30	Enclosure	1. Flush mounting 2. Panel cut-out: (W x H) 182 x 144 mm (max.) 3. Installation Depth: 80 mm (max.) 4. Weight: 0.8 Kg approx.	

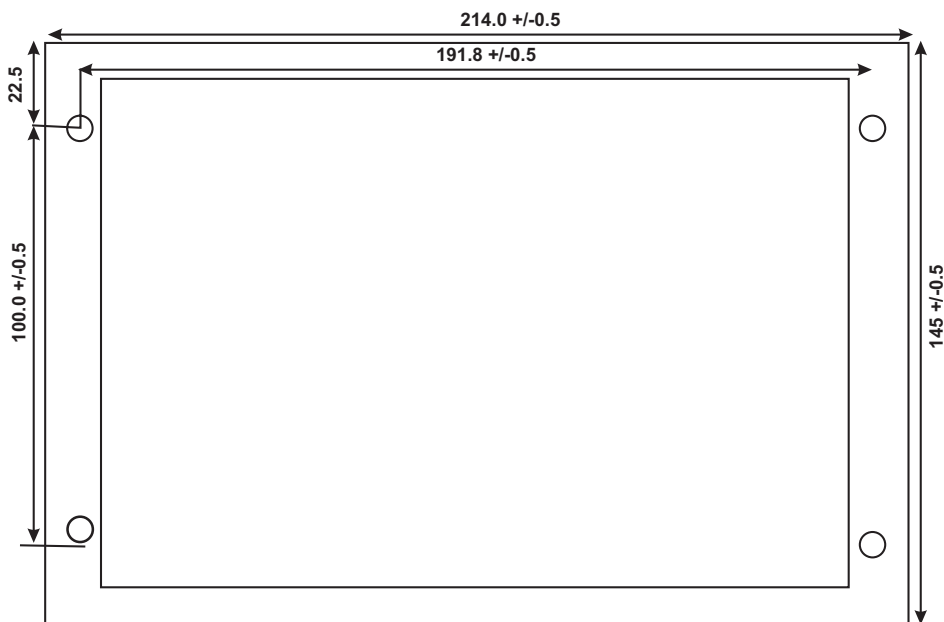

AMF Relay Type : EC2 - FACIA

Panel Cut-out : 182 X 144 (max)
 Installation Depth : 80 (max)
 All dimensions in mm

13. Order Form

AMF Relay		EC2
Version -	V1.5	1.5
	V1.6	1.6
	V1.71	1.71
	V1.10	1.10
as stated in Annex - 1		

Annex - 1

EC2 VERSIONS

EC2 V1.5

We are treating EC2 V1.5 as Standard Version

EC2 V1.6

1. Potential free output contact for start failure-hooter relay has been used for this purpose as follows; the contact across terminal 9, 10 operates only on "fail to start" condition. Hooter function has been disabled.
2. Start delay timer-The present range of the start delay timer is from 0-999 sec. The range has been changed to 0-999 minutes with a step of 1 min
3. Remote mode: In the remote mode the EC2 starts the DG after getting remote start command or at the expiry of "Gen Start Delay" whichever comes first.

EC2 V1.71

1. Default value for MCB CLOSE TIMER is set to 15 sec and generator rated voltage parameter is deleted.
2. MCB will not be closed if any of the phases is having voltage less than mains under voltage parameter.
3. If MCB is switched off because of mains unhealthiness then the MCB open check back is not checked.
4. In single phase operation only if all the phases are not present then only the MCB is made open by EC2.
5. Closure of MCB is not prevented by any fault in DG set.

EC2 V1.10

This is same as V1.5 except that the default mode is 'Auto'. Besides the maximum value of GEN START DELAY has been increased to 9999sec.

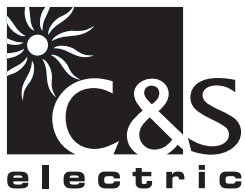

C&S Electric Limited

(Protection & Control Division)

44, Okhla Industrial Estate, New Delhi -110 020 (INDIA)

Phone : +91 11- 66602414, 30883745/54/64 Fax: +91 11- 66602413

E-mail: cspc@cselectric.co.in Web : www.cselectric.co.in

Marketing Offices :

AHMEDABAD: +91 79 30074534/35/36 FAX : +91 79 30074519 **BANGALORE:** +91 80 25586147, 25594939 FAX : +91 25584839
BHUBANESWAR : +91 674 2507265 FAX : +91 674 2507265 **CHANDIGARH :** +91 172 272613, 3062624 FAX : +91 172 2726153
CHENNAI: +91 44 39180531/32/33/34 FAX:+91 44 39180514 **DELHI:** +91 11 30838822-25 Fax:+91 11 30838826 **HYDERABAD :** +91 40 27813003
FAX : +91 40 27812987 **KOLKATA :** +91 33 22275850/51 FAX : +91 33 22275849 **MUMBAI :** +91 22 24114727/28 FAX : +91 22 24126631
NAGPUR : +91 712 5616651 FAX : +91 712 5616651 **PUNE :** +91 20 30283244/45 FAX : +91 20 30283245 **RAIPUR :** +91 771 320852433/34