

Functional Range

LB1 : Load Balancing Relay

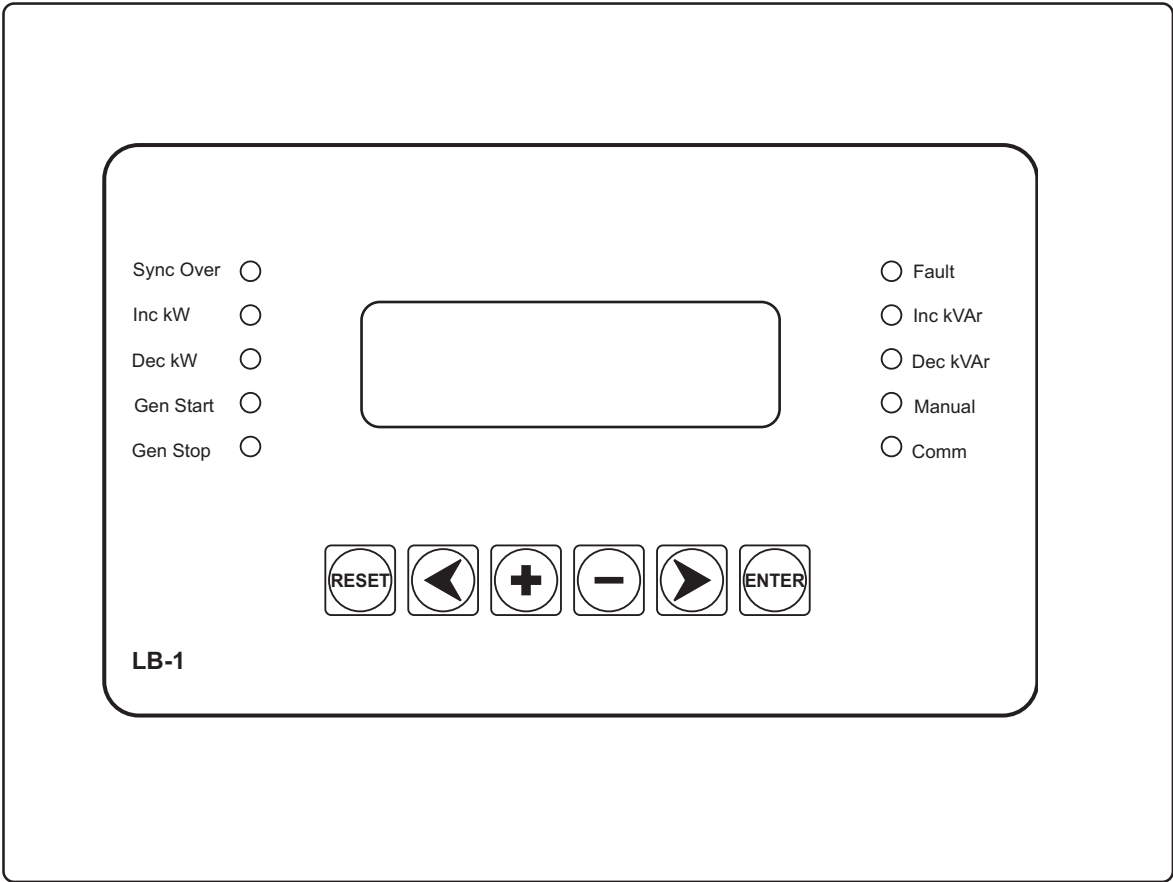

Contents

1 Introduction and Application

2 Features

3 Design

- 3.1.0 Connections
- 3.1.1 Auxiliary supply
- 3.1.2 Analog Input Circuits
- 3.1.3 Output Relays
- 3.1.4 Output Control Circuits
- 3.1.5 Analog Output
- 3.1.6 Digital Inputs
- 3.1.7 Front Plate
- 3.1.8 LCD Display
- 3.2.0 LEDs
- 3.2.1 Key Pad

4 Working Principles

- 4.1 Analog input circuits
- 4.2 Digital circuits
- 4.3 Measuring Principle
- 4.4 Active and Reactive Load Sharing
- 4.5 Load Management
- 4.6 Operating Modes
- 4.7 Operation of active and reactive load control output relays

5 Internal Communication

6 Master Slave Configuration

7 Setting Procedure

- 7.1 Menu Frames
- 7.2 Basic Key Functions
- 7.3 'How to' Guide

8 Technical Data

9 Functional Specifications

10 Performance Specifications

11 Hardware Specifications

12 Terminal Details

- 12.1 Terminal arrangement
- 12.2 Terminal description
- 12.3 Connection Diagram
- 12.4 Dimension

13 Order Form

1 Introduction and application

The Load Balancing Relay type LB1 performs active and reactive load balancing. LB1 also performs load management along with AMF unit and auto-synchronizer. LB1 consists of four elements: measurement, control man-machine-interface and communication. These four elements are integrated into a single unit driven by a powerful 16 bit microcontroller.

The measurement unit continuously measures voltage, current, active power, reactive power, apparent power, power factor and frequency.

The control unit performs four functions:

- On receiving Sync Over command from synchronizing relay, LB1 starts load balancing activity.
- It calculates target value of active and reactive load it must share.
- If it is sharing the desired active load, within a tolerance band, it does not take any corrective action otherwise it controls governor to adjust its share of active power.
- If it is sharing the desired reactive load, within a tolerance band, it does not take any corrective action otherwise it controls Automatic Voltage Regulator [AVR] to adjust its share of reactive power.

The man-machine interface is designed to offer ease of operation and parameter setting, and a clear view of the ongoing processes. It consists of an alphanumeric display, annunciation lamps and soft touch keys arranged aesthetically on the front panel.

The communication unit communicates with other LB1 relays on RS485 communication channel using CSE Open Protocol.

2 Features

- Display of Voltage, Current, Power Factor, Frequency, Active, Reactive and Apparent power.
- LED indications for active/reactive load balancing and manual mode.
- Load dependent start/stop of slave generating set.
- User Selectable Base Load operation
- A user friendly MMI.
- Ability to detect and indicate wrong CT polarity.
- Automatic and manual modes of operation.
- Adjustable ramp allows smooth, time controlled loading.
- Wide setting range with fine steps.
- Wide voltage range for auxiliary supply.
- Serial communication with other units to minimize wiring, external components, space and weight.
- Serial communication with external RTU on RS485 bus.

3. Design

3.1.0 Connections

Please refer to Section 12 for connection diagram.

3.1.1 Auxiliary Supply

Auxiliary supply is connected across terminals 21-22. It accepts a wide voltage range between 16V DC to 360 V DC and 15V AC to 270VAC.

3.1.2 Analog Input Circuits

The single phase voltage of Generator is connected across terminals 1-2 and a CT of the same phase is connected across terminals 24-25. In 3-wire system if voltage is taken from L1-L2 then CT is from L3.

3.1.3 Output Relays

LB1 has seven output relays. All functions and terminals of these output relays are described in the Table 1 shown below. Please also see control options in 3.1.4.

Relay No.	Description	Terminal NO.
1	Hooter/Alarm	7,8
2	Governor \uparrow	9,10
3	Governor \downarrow	11,12
4	AVR \uparrow	13,14
5	AVR \downarrow	15,16
6	Gen Start	19,20
7	Gen Stop	17,18

Table 1: Output relay description

3.1.4 Output Control Circuits

There are several options available for controlling AVR and governor. The options are: Potential free contact, Voltage signal ($\pm 1V/\pm 3V/\pm 9V/0-5V$) and Current Signal (4-20mA).

Any combination of the above mentioned options is available. Please refer to section 13 for ordering information of LB1.

3.1.5 Analog Output

Output Type: Current	4-20 mA
Tolerance	$\pm 5\%$
Max load resistance	300 Ω
Resolution	> 11 bits.
Output Type: Voltage	0-5, $\pm 1V$, $\pm 3V$, $\pm 9V$
Tolerance	$\pm 5\%$
Minimum load resistance	1k Ω
Resolution	> 11 bits

3.1.6 Digital Inputs

There are four optically coupled digital inputs as described below:

- 1) 'Sync Over': This input comes from synchronizing relay. Synchronizing relay issues this signal when the generator is successfully synchronized with bus. The digital input Sync Over is connected across terminals 30-31 respectively.
- 2) 'Auto / Manual': This mode is used to select the mode of operation. In this mode 'start', 'stop' and load balancing functions are performed manually. This mode is selected by shorting 'Auto/Manual' terminal to 'Common' terminal.
- 3) 'Master / Slave': This is used for selecting Master LB1. The digital input Master/Slave is shorted to 'Common' terminal.
- 4) 'Base Load Mode'. In this mode LB1 supplies a specified amount of KW to the bus at specified KVAR. Desired KW and KVAR are selected from MMI. This mode is selected by the application of voltage greater than 80VAC [$<$ maximum sensing voltage] at terminals 3-4.

3.1.7 Front Plate

The front plate is aesthetically designed and ergonomically laid out with two columns of five LEDs on either side, a large LCD panel in the top center and a row of keys just below it.

3.1.8 LCD Display

There is a large back-lit LCD display having four lines of twenty alpha-numeric characters to display voltage, current, frequency, faults, names and values of parameter etc.

3.2.0 LEDs

There are ten LEDs for annunciation: Sync Over, Inc kW, Dec kW, Gen Start, Gen Stop, Fault, Inc kVAr, Dec kVAr, Manual, Comm.

Functions of these LEDs are described in the following table:

LEDs	OFF	ON / FLASHING
Sync Over	'Sync Over' not received	Sync Over command received
Inc kW	No 'Increment kW' Signal to Governor	'Increment kW' Signal to Governor active
Dec kW	No 'Decrement kW' Signal to Governor	'Decrement kW' Signal to Governor active
Inc kVAr	No 'Increment kVAr' Signal to AVR	'Increment kVAr' Signal to AVR active
Dec kVAr	No 'Decrement kVAr' Signal to AVR	'Decrement kVAr' Signal to AVR active
Fault	No Fault	Communication fails, AVR fails to respond, Governor fails to respond, CT polarity is wrong, Synchronization failure, Voltage unhealthy, [Comm. fail is displayed in master only]
Gen Start	Start generator command not issued	Start Generator command issued
Gen Stop	Stop generator command not issued	Stop Generator command issued
Manual	Operating in auto mode	Operating in 'Manual' mode
Comm	No Communication	Communication Active: Master Comm LED will glow steady, while slave Comm LED will keep on blinking. Blinking indicates that slave LB-1 is communicating with the master.

3.2.1 Key Pad

A user friendly interactive MMI has six soft-touch keys and the LCD screen as described above. The RESET key provides following functions:

- If AVR or Governor fails to respond, then after pressing the RESET key ramp action is again started.
- If any of the fault occurs hooter is activated. The RESET key can be pressed to silence the hooter.

Other five keys are used in edit operation. The keys are "<", "+", "-", ">" and "ENTER". The keys marked "<" and ">" are meant for backward and forward scrolling respectively. Data or function is selected by pressing "ENTER" key. The keys marked "+" and "-" are used for decrementing and incrementing selected parameter value.

4 Working Principles

4.1 Analog Input Circuits

These voltages are galvanically isolated with the help of transformers. The noise signals caused by inductive and capacitive coupling are suppressed by analog R-C filters. The filtered signals are fed to analog-to-digital converters of the microcontroller through sample-and-hold circuits. The analog signals are sampled at a rate of 40 samples per cycle.

4.2 Digital Circuits

Once the data is available in digital form it is processed by the 16 – bit microcontroller. The microcontroller processes currents and voltages at the analog inputs and then based on the measured values calculates the existing power.

The setting values are preserved in a non-volatile memory (EEPROM – Electrically Erasable Programmable Read Only Memory) so that actual relay settings are not lost even if auxiliary supply is interrupted.

The microcontroller is supervised by a built in watchdog timer. In case of a failure the watchdog timer resets the microcontroller.

4.3 Measuring Principle

Through multiplication of the actual current and voltage values $p(t) = v(t) \times i(t)$, the microcontroller calculates the phase power. 40 instantaneous values are measured and recorded per cycle.

$$P = \frac{1}{T} \int P(t) \cdot dt$$

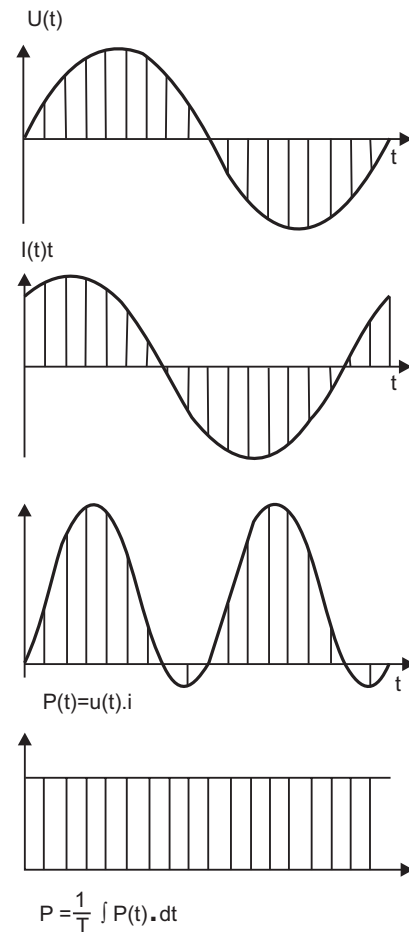

Fig. 1

4.4 Active and Reactive Load Sharing

LB1 starts operation after it receives 'Sync Over' command and works as follows:

- There is one LB1 for every generator on the bus.
- The LB1 relays are connected together on serial bus (RS485) and communicate with each other using CSE Open Protocol.
- One LB1 is a master unit of RS485 links other connected LB1 relays are slave units of RS485 link.
- Each LB1 measures voltage, frequency, current, power factor, reactive power and active power of the generator and if it is a slave unit, then it supplies active power & apparent power to master unit.
- Thus master unit possesses all accessed information of all generators.
- Master unit calculates system capacity and system load and distributes this information to all slaves.
- Based on the information about their own generator and information gathered from the master, each slave calculates target value of active and reactive load it must share.

- If it is sharing the desired load, within a tolerance band, it does not take any corrective action otherwise it controls governor to adjust share of active power or controls AVR to adjust its share of reactive power.
- Share of active power and reactive power is governed by following relations:

$$kW_{share} = \frac{[(SYSloadkW/SYScapkW) \times GENcapkW]}{GENcapkW}$$

where

- SYSloadkW = sum of Load kW on all active generators.
- SYScapkW = sum of Capacity KW on all active generators,
- GENcapkW = Capacity of the generator in kW.
- KVAshare = $\frac{[(SYSloadkVA/SYScapkVA) \times GENcapkVA]}{GENcapkVA}$
- SYSloadkVA = sum of Load kVA on all active generators
- SYScapkVA = sum of Capacity kVA on all active generators
- GENcapkW = Capacity of the generator in kva.

A unit is said to be active if it has received 'Sync Over' command or its current has exceeded 2% of I_N . In manual mode active power /reactive power can be changed irrespective of the status of synch over command.

Example:

For example if there are two units online.

Master GENcapkVA	:	1875kVA
Master GENcapkW	:	1500kW
Slave GENcapkVA	:	1250kVA
Slave GENcapkW	:	1000kW
SYSloadkW	:	1000kW
SYScapkW	:	2500KW
SYSloadkVA	:	1250kVA
SYScapkVA	:	3125kVA
kW Hysteresis	:	5%
kVA Hysteresis	:	10%

In this case, master generator will take 750(in the band: 825-675) kVA* & 600(in the band: 570 - 630) kW*. Slave generator will take 500(in the band: 450-550) kVA* & 400(in the band: 380-420) kW*.

[*Considering hysteresis]

- It gives 'Increase kW' or 'Decrease kW' command to governor, depending on whether kW of generator is below or above the kW share.
- It gives 'Increase kVA' or 'Decrease kVA' command to the AVR, depending on whether kVA of generator is below or above the kVA.
- It repeats this process as long as the kW and kVA difference does not fall within kW hyst and kVA hyst setting respectively.

4.5 Load Management

The LB1 also performs load management function in Automatic mode of operation.

Load management involves turning off a DG when system load falls below a set value and turning it on when system load exceeds a preset high value. Prior to turning off a DG, its load is smoothly cut off. A relay turns off its associated DG after it gets a command from master. It starts its own DG when master sends command to it.

4.5.1 Start Stop Sequencing Logic

The genset to be started or stopped will depend upon the Slave address sequence entered in START STOP SEQ Menu. The Slave Address written at the top of the menu will be started first and stop Last (LIFO Scheme)

The unit which is "Disabled" or "not communicating" or configured in "Manual Mode" will not be included in the auto start/stop sequence with other Load Balancing units connected to the bus. One LB1 is associated with each generator.

A Slave number (Slave NO.) is assigned to every LB1 relay. If we wish to start generators in the sequence: Slave 1- Slave 2- Slave 3- Slave 4 then Slave Address Sequence Menu should be like this:-

```
# START STOP SEQ #
SLAVE No 1
SLAVE No 2
SLAVE No 3
SLAVE No 4
```

This will have following result:

First Slave 1 will start. If its load exceeds kWmax, then it will wait for a period equal to TLDmax and then, via master, Slave 2 will be started, synchronized and balanced. If load on generator1 or generator2 exceeds its kWmax, then after a delay of its TLDmax, Slave 3 will come on to the bus.

At this point, if load on any generator falls below that generator's kWmin, then after a delay of TLDmin, Slave 3 will be switched off.

Now if load on any generator exceeds that generator's kWmax, then next generator to start will be Slave 3 .Refer fig 4

4.5.2 Starting of Generator

When load (kW) on any generator exceeds its specified maximum limit (kWmax) and if this condition continues for a specified time (TLDmax), then its corresponding LB1 requests master to start the next generator (unless this relay is itself the master). The master tells an appropriate LB1 on serial link to start its generator. The addressed (slave) LB1 issues Start command to its associated AMF relay; at this point slave starts the Sync Fail timer and master starts the Next Start timer. Generator takes some time to synchronize and therefore these timers are included.

This AMF relay starts the generator and when generator develops correct voltage and frequency, it activates the synchronizing relay. The synchronizing relay synchronizes the generator with the bus and then sends 'Sync Over' command to the selected LB1.

Suppose 'Load High' (to start DG) is received again and if Next Start timer has not elapsed then master doesn't send start command to any [other] relay.

Suppose the LB1 does not receive Sync Over command before Sync Fail timer expires then slave sends the Sync Fail status to the master. Then master sends start command to next unit as per the sequence. Thus next LB1 comes into action.

In case the load on a generator stays above its rated kW for a period TRLD then request for starting next generator is issued.

TRLD is kept much less than TLDmax because exceeding rated kW can not be allowed for a long time.

4.5.3 Stopping of Generator

When load (kW) on a generator falls below its specified minimum load (kWmin) and if this condition continues for a specified time (TLDmin), then its LB1 requests the master for shut down. Many relays might simultaneously send such a request. Master decides which generator should be shut down. The master tells the appropriate LB1 on serial link to shut down its generator. The addressed LB1 then issues Stop command to its associated AMF relay after the active and apparent power on its associated generator is reduced to StopKW% of its rated kVA and rated kW respectively. The duration of stop pulse is specified as GenStop time.

LB1 sends this information to the master. Master Generator takes some time to un-load; therefore on receiving this information LB1 starts the NEXT STOP timer. Suppose load low is received again and this timer has not elapsed, then master doesn't send stop command to any other relay.

4.6 Operating Modes

LB1 operates in one of the two modes described below.

These two modes are:

- a) Auto mode
- b) Manual mode

Auto mode:

In Auto mode the load balancing actions namely, kW control and kVAr control are automatically performed. The load management functions namely, request for shut down and request for starting next generator are automatic if auto mode is enabled.

Manual mode:

Manual mode allows the user to manually adjust kW and kVAr. User can select the function as follows: First press enter on "Mode Selection" and then select "Manual Mode".

To adjust kW: select "kW Control" by pressing enter on this option and then use '+' / '-' keys to increase/ decrease kW.

To adjust kVAr: select "kVAr Control" and then use '+' / '-' keys to increase/ decrease kVAr.

To start Gen, select Start Gen function and press Enter key.

To stop itself: select Stop Gen function and press Enter key.

4.7 Operation of active and reactive load control output relays.

When one of the operating conditions is met (to either increase or decrease the active/reactive load) the pulse cycle of the appropriate output relay is started.

- The cycle is repeated after Pulse Off time
- The relay remains energized for not less than the Min Pulse time and not longer than the Max Pulse time.

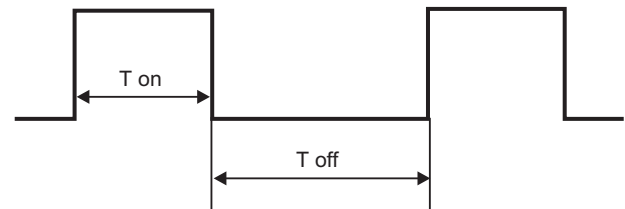

Min Pulse \geq T on \leq Max Pulse
 T off = Pulse off

Fig. 2

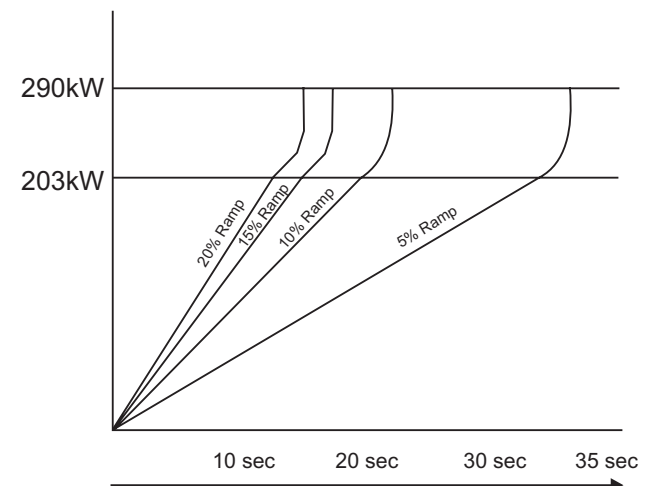

Fig. 3

Example

Suppose there are 2 relays i.e. Relay1 and Relay 2, Relay1 is the master and Relay 2 is the slave.

- Target load for relay 2 : 290kW
- Target for ramping : 70%of 290kW =203kW
- Ramp kW setting : 5%,
- Min. pulse setting : 0.4
- Max. pulse setting : 2 sec,
- Pulse Off time setting : 2 sec

Microcontroller calculates the pulse width required for a change of 5% of the target load (14.5kW). Suppose the pulse width comes out be 0.4 sec. 14 steps will be required to reach the target of 203 kW. Therefore total time required will be calculated as follows :

No of steps (pulse width + pulse off time) = 14 (0.4 + 2) = 33.6 sec.

With the assumption that the pulse width required for a change of 5% of target load is 0.4 sec., therefore pulse width required for 10 % change will be 0.8 sec. Minimum pulse width will be 0.8 sec.

For 10% Ramp setting time required will be 7 (0.8 +2) = 19.6 sec.

As explained above pulse width required for 15% change will be 1.2 sec

For 15% Ramp setting time required will be 5 (1.2 +2) = 16 sec

Minimum Pulse Width = 1.6 sec

Similarly for 20% Ramp setting time required will be 4 (1.6 +2) = 14.4 sec

Now PI algorithm will be implemented to achieve actual target of 290 kW

5 Internal Communication

There is a communication link between all relays.

The relays are able to communicate on RS485 bus under CSE Open Protocol. One of these relays is a master and remaining relays are slaves.

6 Master Slave Configuration

By default all relays are slaves. A relay can be configured as master by using DI input Master / Slave switch to CONFIGURE AS MASTER. Suppose some relay is to be made master then the current master should be converted to slave; as the master has to inform all relays that it is no longer master and this takes 1 seconds.

7 Setting Procedure

7.1 Menu Frames

Default Page Menu 1 (Running Parameters)	MASTER/SLAVE No. PRIMARY SIDE: kVA kVAR kW XXXX XXXX XXXX VOLTAGE : XX.XXXX kV CURRENT : XXXXX A SECONDARY SIDE : VA VAR W XXXX XXXX XXXX VOLTAGE : XXX V CURRENT : X.XXX A FREQ : XXX.XX PF: 0.XX LAG/LEAD/UNITY SYSCAP KW: XXXX SYSCAP KVA: XXXX SYSLOAD KW: XXXX SYSLOAD KVA: XXXX FAULT : MODE: XXXX
Menu 2 (Pressing Enter Key)	MODE SELECTION EDIT/VIEW PARAMETERS MASTER MENU HOOTER ASSIGNMENT LOAD DEFAULT CHANGE PASSWORD BACK TO PREV PAGE
Menu 3 (Pressing Enter Key on MODE SELECTION)	MANUAL MODE BACK TO PREV PAGE
Menu 4 (Pressing Enter Key on MANUAL MODE)	GEN START GEN STOP kW CONTROL kVAR CONTROL BACK TO PREV PAGE
Menu 5 (Pressing Enter Key on GEN START)	MODE : MANUAL GEN START BACK TO PREV PAGE
Menu 6 (Pressing Enter Key on GEN STOP)	MODE : MANUAL GEN STOP BACK TO PREV PAGE

Menu 7 (Pressing Enter Key on kW CONTROL) to increase, decrease kW press '+','-'	MODE : MANUAL kW CONTROL kVA kVAR kW XXXX XXXX XXXX BACK TO PREV PAGE
Menu 8 (Pressing Enter Key on kVAR CONTROL) to increase, decrease kVAR press '+','-'	MODE : MANUAL kVAR CONTROL kVA kVAR kW XXXX XXXX XXXX BACK TO PREV PAGE
Menu 9(Pressing Enter Key on Edit/View Mode)	# EDIT PARAMETERS # UNIT SLAVE NO. RATED kW RATED kVA PT RATIO CT RATIO WMAX WMIN TLDMAX TLD MIN TRLD NEXT START NEXT STOP kW HYST kVA HYST Kpa Kpap TSYNC RAMP KW RAMP KVA UNDER VOLT. OVER VOLT. STOPKW GEN STOP. SYNC FAIL KWCT MIN PULSE MAX PULSE PULSE OFF KW CONTROL KVAR CONTROL HOOTER RST BASE LOAD KW BASE LOAD KVAR MANAGEMENT RS 232 / 485 RTU SLAVE BACK TO PREV PAGE
Menu 10	Save modification? YES NO CANCEL
Menu 11	Enter PASSWORD
Menu 12	SAVING ...
Menu 13	Enter Password ! INVALID PASSWORD!

Menu 14 (Pressing Enter Key on MASTER MENU)	SEQUENCING MENU UNIT STATUS BACK TO PREV PAGE
Menu 15 (Pressing Enter Key on SEQUENCING MENU)	# START STOP SEQ # SLAVE NO. SLAVE NO. SLAVE NO. SLAVE NO. SLAVE NO. SLAVE NO. SLAVE NO. SLAVE NO. BACK TO PREV PAGE
Menu 16 (Pressing Enter Key on UNIT STATUS)	SL ACT FAULT 1: ON/OFF NO FAULT/FAULT 2: - do - 3: - do - 4: - do - 5: - do - 6: - do - 7: - do - 8: - do - SL. MODE DISABLE 1: AUTO/MANUAL YES/NO 2: - do - 3: - do - 4: - do - 5: - do - 6: - do - 7: - do - 8: - do - SL. CapkVA CapkW 1: XXXX XXXX 2: - do - 3: - do - 4: - do - 5: - do - 6: - do - 7: - do - 8: - do - UNIT LoadkVA LoadkW 1: XXXX XXXX 2: - do - 3: - do - 4: - do - 5: - do - 6: - do - 7: - do - 8: - do - BACK TO PREV PAGE

Menu 17(Pressing Enter Key on HOOTER ASSIGNMENT)	<p>HOOTER ASSIGNMENT</p> <p>[] CT FAULT</p> <p>[] VOLTAGE FAULT</p> <p>[] AVR FAULT</p> <p>[] GOV FAULT</p> <p>[] SYNC FAIL FAULT</p> <p>[] COMM FAULT</p> <p>Means Hooter relay is not assigned to the corresponding parameter. In order to assign Hooter relay press INC/DEC key display shows[*] CT FAULTThe assignment can be saved by pressing ENTER and subsequent input of the password.</p>
Menu 18(Pressing Enter Key on LOAD DEFAULT)	Enter Password
Menu 19	Loading . . .
Menu 20 (Pressing Enter Key on CHANGE PASSWORD)	Enter PASSWORD
Menu 21	Enter new PASSWORD
Menu 22	Re-Enter PASSWORD
Menu 23	SUCCESS : PASSWORD CHANGED!

7.2 Basic Key Functions

KEY	FUNCTION
RESET	Reset annunciation / relay
←	Previous item / menu
+	Increment selected quantity / check the box
-	Decrement selected quantity / check the box
➤	Next item / menu
ENTER	Confirm selection of item in the menu / save value

- All keys can be used in selecting/specifying password
- Pressing Reset key for 2 sec., cursor will go back to the previous page.

7.3 'How to' Guide

How to	KEY TO BE PRESSED	MENU DISPLAYED
View Running Parameters	Do not touch any key for 2 minutes; running parameters will appear on the screen after applying the auxiliary supply to LB-1.	Menu 1
Edit Parameters of desired function	If you are in menu 1 then Press ENTER key and using → & ← keys bring cursor/blinking on EDIT/VIEW PARAMETERS option. Select this menu by pressing ENTER key.	Menu 2
	Scroll through different functions using → & ← keys. By using INC & DEC keys parameters value can be increased or decreased.	Menu 9
Configure relay as Master or slave and then edit master or slave menu	By pressing ENTER key LB-1 will ask whether to save the edited parameter.	Menu 10, 11, 12
	Press → Or ← key to move to YES, NO or CANCEL. If YES is selected by pressing ENTER	
	LB1 will ask for password. Enter the password and the parameter will be saved. Select the option MASTER MENU from Menu 2 by pressing ENTER key and a new menu will pop up displaying	Menu 2
	In case MASTER option is selected display shows SEQUENCE MENUUNIT STATUS	Menu 14
	After selecting SEQUENCE MENU enter the sequence in which units are to be started or stopped.	Menu 15
	The assignment can be saved by pressing ENTER and subsequent input of the password.	Menu 19
	UNIT STATUS Menu displays the status of all Slaves.	Menu 16

Select Auto/Manual	Select the MODE SELECTION from menu 2, by pressing ENTER.	Menu 2
	LB1 will display Menu 3, Menu 4 will appear. In case of Manual mode, Menu 5 will appear.	Menu 3
	Selection of kW Control/ KVAR Control will display Menu 8/ Menu 9. Using INC/DEC keys, active and reactive load can be changed.	Menu 4
	Selection of GEN START/GEN STOP will display Menu 6/ Menu 7. By pressing ENTER key generator can be started/ stopped	Menu 5
		Menu 7, Menu 8 Menu 6
		Menu 7

8 Technical Data

Table 3 : Parameter settings in Edit mode

Description	Displayed As	Range	Steps	Default Setting
Disable or Enable the Unit: The unit which is disabled will not be included in the auto stop/start sequence with other Load balancing units connected to the bus. This applies to manual mode also. Note: In case a unit is disabled manual mode can not be selected.	UNIT	DISABLE/ ENABLED	1	ENABLED
Every unit must have a unique slave number. Note: # indicates that the relay is not assigned any slave number.	SLAVE NO	1 - 8	1	#*
kW Rating of DG associated with relay	RATED KW	1 - 9999	1	400
kVA Rating of DG associated with relay	RATED KVA	1 - 9999	1	500
PT Ratio	PT RATIO	1.0-100.0	0.1	1.0
CT Ratio	CT RATIO	1-9999	1	160
Maximum load level: Percent of generator load at which one unit should be sequenced On.kWshare = [(SYSloadkW / SYScapkW) x GENcapkW] Max load level = (Gen capacity x Wmax) / 100. When kW on Gen is greater than KWshare as well as Max load level then it will send START request to master.	WMAX	1%-99%	1%	65%
Minimum load level: Percent of generator load at which one unit should be sequenced Off.kWshare = [(SYSloadkW / SYScapkW) x GENcapkW] Min load level = (Gen capacity x Wmin) / 100. When kW on Gen is less than Kwshare as well as min load level it will send STOP request to master.	WMIN	1%-99%	1%	30%
Maximum_load delay: When kW > kWshare and kW > Max load level is true for a duration greater than TLDmax seconds then it will send START request to master.	TLDMAX	1-1200Sec	1sec.	10 sec.
Minimum_load delay: When kW < kWshare and kW < Min load level is true for a duration greater than TLDmin seconds then it will send STOP request to master.	TLDMIN	1-1200Sec	1sec.	60 sec.

Rated_load delay: When kW > kWshare and kW > Gen Capacity is true for a duration greater than TRLD seconds then it will send START request to master.	TRLD	1-1200 sec.	1sec.	10 sec.
Start_NEXT_Generator_Time: A timer is enabled in the master LB-1 when it transmits a message to the slave to start the DG, as the upcoming DG requires some time to get synchronized with the bus-bar and to actually start supplying power.	NEXT START	1-1200 sec.	1sec.	180 sec.
Stop_Next_Generator_Time: This is the time required to ramp the load down to STOPKW % level; after this time it will issue stop command to AMF relay.	NEXT STOP	1-1200 sec.	1sec.	60 sec.
Active_Load_Sharing hysteresis: Hysteresis indicates the dead zone and no control action is taken if load is within the band, otherwise it controls governor to adjust its share of active power (kW).	KW HYST	5-20%	1%	10%
Apparent_Load_Sharing hysteresis: Same as above but applicable to kVA	KVA HYST	5-20%	1%	10%
kW sharing proportional gain: Kpa is used to make the response of the governor fast or slow.	Kpa	0.01-2.00	0.01	0.1
VA Sharing proportional gain: Kpap is used to make the response of the AVR fast or slow.	Kpap	0.01-2.00	0.01	0.1
Sync over start delay: This timer is started after receiving the sync over command; after this it will start load sharing.	TSYNC	1-99 sec.	1sec.	1 sec.
Ramp Kw: This value specifies the Slope of Ramp over its full range.	RAMP KW	5-20%	1%	10%
Ramp Kva: This value specifies to change the Slope of Ramp over its full range.	RAMP KVA	5-20%	1%	10%
Under Volt: Under voltage. If the generator voltage is less than Under voltage, then it will raise the fault.	UNDER VOLT	50-500	1	50
Over Volt: Over voltage. If the generator voltage is more than Over voltage, then it will raise the fault.	OVER VOLT	50-500	1	500
STOPKW: When master LB1 intimates the slave to stop DG, the slave will ramp off [decrement the load] and then it will check the set point [generator capacity KW x STOPKW / 100]. If load on DG is less than set point it will issue stop command to AMF Relay.	STOPKW	10-99%	1	30%
GENSTOP: It is the time when the LB1 will issue the Stop command	GENSTOP	2-300sec.	1sec	10 sec.
Sync Fail: This time starts when master intimates the slave to start the DG.	SYNC FAIL	10-3600 sec	1	500
KWCT (Reverse power). It is the percentage of Generator capacity KW. When the load on LB1 exceed the set percentage of KWCT then it will raise CT POLARITY fault.	KWCT	-(1-99)%	1	-5%
Minimum Pulse Width: Minimum pulse width for output relay operation.	MIN PULSE	0.1-4.0sec.	0.1 sec.	0.2 sec.
Maximum Pulse Width: Maximum Pulse width for output relay operation. Note: Ensure that Max Pulse setting is greater than Min Pulse.	MAX PULSE	0.1-5.0 sec.	0.1sec.	1.3 sec.
Minimum Pulse Off Time: Next Pulse width coming after this time.	PULSE OFF	1-50 sec.	1sec.	2 sec.
KW control: Enable or Disable the active power control.	KW CONTROL	ENABLE/ DISABLE		ENABLE
Kvar control: Enable or Disable the reactive power control.	KVAR CONTROL	ENABLE/ DISABLE		ENABLE

Hooter Reset Period: It starts as soon as the hooter starts. If hooter is not silenced with in hooter reset period then at the expiry of this period hooter is automatically stopped.	HOOTER RST	1-1200sec	1sec	20 sec.
Base Load kW: When DG is coupled with the mains, then it is required to supply this amount of power.	BASE LOAD KW	1-9999	1	400
Base Load KVAR: When DG is coupled with the mains, then it is required to supply this amount of reactive power.	BASE LOAD KVAR	1-9999	1	300
Management: Enable OR Disable load dependent start / stop.	MANAGEMENT	ENABLE/DISABLE		ENABLE
RS-232 / 485 Selection	RS-232-485	232/485		485
RTU Slave	RTU SLAVE	1-32		1

- Default Password for LB1 is 'ENTER-ENTER-ENTER-ENTER'

9 Functional Specifications

S.No.	Parameter	Specification		
1	Selection Mode	Auto	In Auto mode kW control and kVAr control functions are all automatic	
2		Manual	Manual mode allows the user to manually adjust kW and kVAR Also generator can be started or stopped manually.	
3	Function	View Running Parameters (Default Display)	Master / Slave No.	
4			Primary Side	
5			kVA	
6			kVAR	
7			kVA	
8			Voltage (RMS value)	
9			Current (RMS value)	
10			VA	
11			VAR	
12			W	
13			Voltage	
14			Current	
15			Frequency	
16			Power Factor Lag/Lead indication/Unity	
17			System Capacity In kW	
18			System Capacity In kVA	
19			System Load In kW	
20			System Load In kVA	
21			Fault	
22			Mode: LB-1/Base Load	
23			UNIT	
24			SLAVE NO.	
25	RATED kW			
26	RATED kVA			

27			PT RATIO	
28			CT RATIO	
29			WMAX	
30			WMIN	
31			TLDMAX	
32			TLD MIN	
33			TRLD	
34			NEXT START	
35			NEXT STOP	
36			kW HYST	
37			kVA HYST	
38		<p>View / Set Parameters</p> <p>These parameters can be edited under password protection</p>	Kpa	
39			Kpap	
40			TSYNC	
41			RAMP KW	
42			RAMP KVA	
43			UNDER VOLT.	
44			OVER VOLT.	
45			STOPKW	
46			GENSTOP.	
47			SYNC FAIL	
48			KWCT	
49			MIN PULSE	
50			MAX PULSE	
51			PULSE OFF	
52			KW CONTROL	
53			KVAR CONTROL	
54			HOOTER RST	
55			BASE LOAD KW	
56			BASE LOAD KVAR	
57			MANAGEMENT	
58			RS 232 / 485	
59			RTU SLAVE	
60			Master Menu	To view the status of all LB1 relays. And to set the start stop sequence.
61			Hooter Assignment	Hooter relay can be assign to any fault.
62			Change Password	Password can be modified. Default Password for LB-1 is 4 times ENTER key.
63			Load Default	Default parameters and default password is loaded

10 Performance Specifications

S.No	Parameter	Specification
1	Aux Supply	16V-270V AC/ 16-360V DC
2	Aux supply burden	< 6VA
3	Nominal Voltage	110V / 80-130VAC 230V / 200-260VAC [Standard] 400V / 360-440VAC
4	Accuracy in Voltage Measuring	+/-1%
5	Accuracy in Current Measuring	+/-0.5%
6	Rated frequency	50 Hz
7	Nominal Current	1A /5A
8	C. T. Burden	<1VA

Note : In 3-wire system if voltage is taken from L1-L2 then CT is from L3.

11 Hardware Specifications

S.No	Parameter	Specification	Remarks
1	Display	20 characters/row x 4 rows LCD display with built in controller	
2	Annunciation using LEDs (10 numbers)	Sync Over, Inc kW , Dec kW, Gen Start, Gen Stop, Fault, Inc kVAr, Dec kVAr, Manual, Comm.	
3	Key Pad 6 Keys	<, +, -, >, Enter, Reset	
4	Controls: Opto-	Sync Over, Auto / Manual, Master / Slave, Base Load Mode	Isolated I/Ps – 4:
5	Relay – 7 nos. Option-1	250VAC 5A / 24V DC AVR↑ , AVR ↓, GOV↑, GOV↓ , Gen Start, Gen Stop & Hooter	These options will be available through ordering info.
6	Current Loop O/P Option-2	4-20mA (Max load resistance:300R)	These options will be available through ordering info.
7	DC Voltage O/P Option-3 thru 6	+/-1, +/-3, +/-9, 0-5 VDC (Max. Load Resistance 1K)	These options will be available through ordering info.
8	Communication	RS485-CSE Open Protocol for internal communication RS 485/RS 232 Modbus Protocol for external communication.	There is a communication link between all relays. One of these relays is a master and remaining relays are slaves. CSE Open Protocol is used in their communication.
9	Storage temp.	- 40°C - +75°C	
10	Operating Temp	- 20°C - +70°C	
11	Connecting terminals	max 2.5 mm ² Recommended 2.5 mm ² conductor	
12	Enclosure	1. Flush mounting 2. Panel Cut-Out: (W x H) 178 x 140 mm 3. Dimensions: (W x H x D) 214 x 140 x 80 mm 4. Weight: 1.2 Kg appx.	

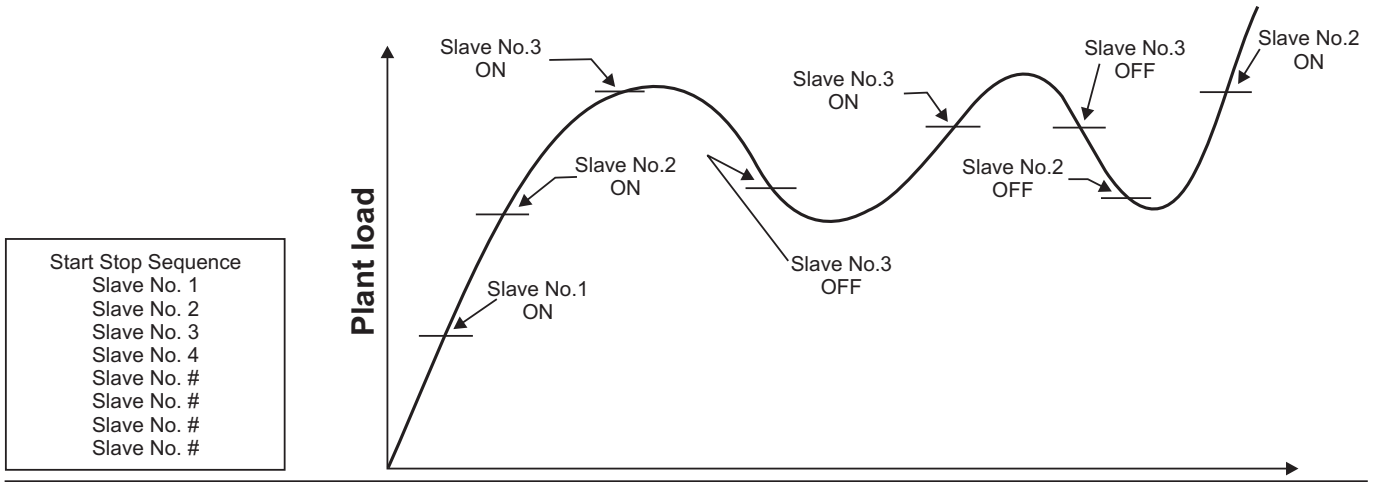
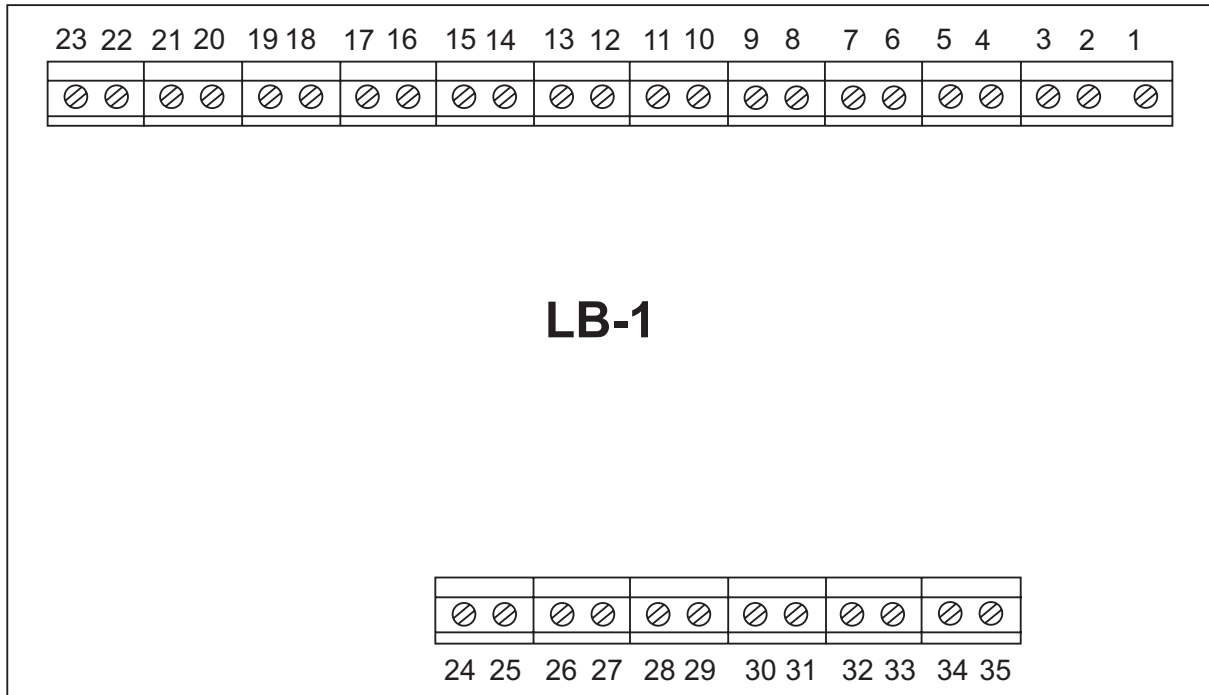

Fig. 4

12 Terminal Details

12.1 Terminal arrangement

The terminal arrangement of the LB1 is shown in the figure shown.



Terminal Arrangement viewed from Rear

12.2 Terminal description

Terminal No	Description According to Model		
	LB1 -RX	LB1 -CX	LB1 -VX
1	Generator Voltage	Generator Voltage	Generator Voltage
2	Generator Voltage	Generator Voltage	Generator Voltage
3,4	Base Load Mode	Base Load Mode	Base Load Mode
5,6	X	X	X
7,8	Hooter/Alarm contact	Hooter/ Alarm contact	Hooter/ Alarm contact
9,10	Governor \uparrow	X	X
11,12	Governor \downarrow	4-20mA, GND	($\pm 1V/\pm 3V, \pm 9 V/0-5V$), GND
13,14	AVR \uparrow	X	X
15,16	AVR \downarrow	4-20mA, GND	$\pm 1V/ \pm -3V/ \pm 9 V/ 0-5V$, GND
17,18	Generator Stop Command	Generator Start Command	Generator Start Command
19,20	Generator Start Command	Generator Stop Command	Generator Stop Command
21,22	Auxiliary supply	Auxiliary supply	Auxiliary supply
23	Earth	Earth	Earth
24,25	CT	CT	CT
28	Master/Slave	Master/Slave	Master/Slave
29	Auto/Manual	Auto/Manual	Auto/Manual
30	Sync Over	Sync Over	Sync Over
31	Comm. for 28,29,30	Comm. for 28,29,30	Comm. for 28,29,30
32,33	RTU (P,N)	RTU (P,N)	RTU (P,N)
34,35	Int. Comm. (With other LB1)	Int. Comm. (With other LB1)	Int. Comm. (With other LB1)

12.3 Connection Diagram

LB1-RX ELECTRICAL CONNECTION is as Shown in the Fig. given Below :

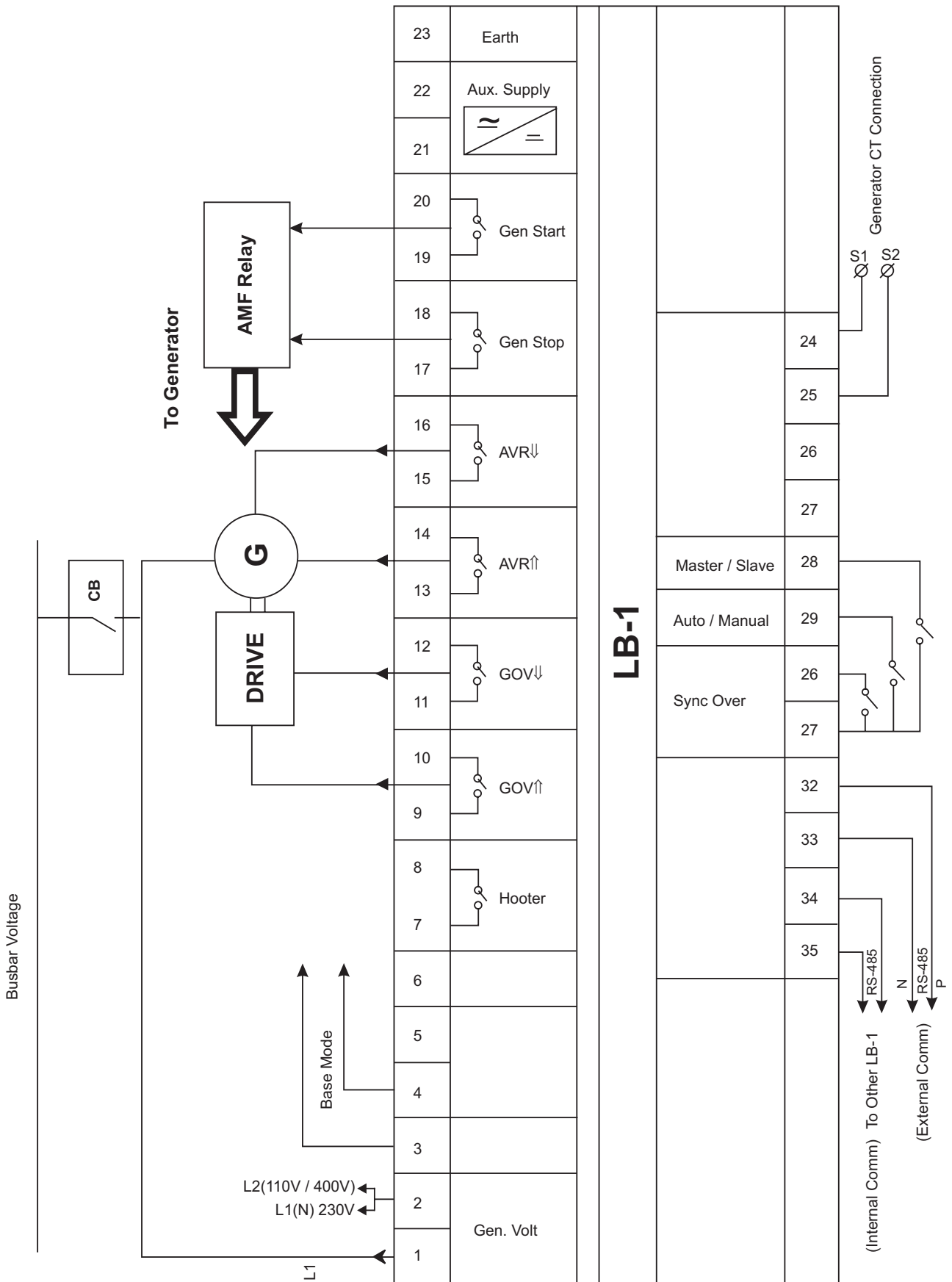

In LB1-CX Model, all electrical connections are same as in LB1-RX except AVR/GOV connections, as per shown figures

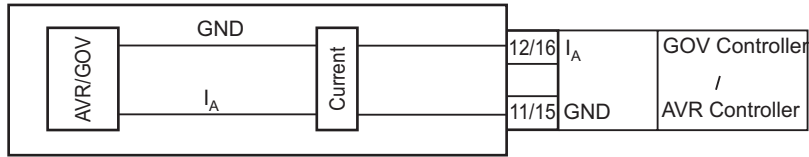

In LB1-VX Model, all electrical connections are same as in LB1-RX except AVR/GOV connections, as per shown figures

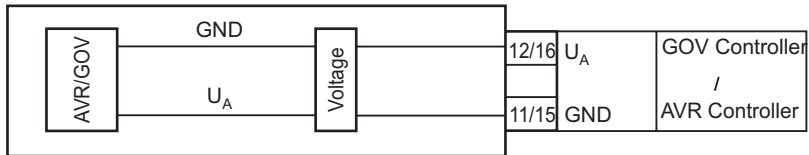

Connections of four LB1 Units are as per shown in Figure given below :

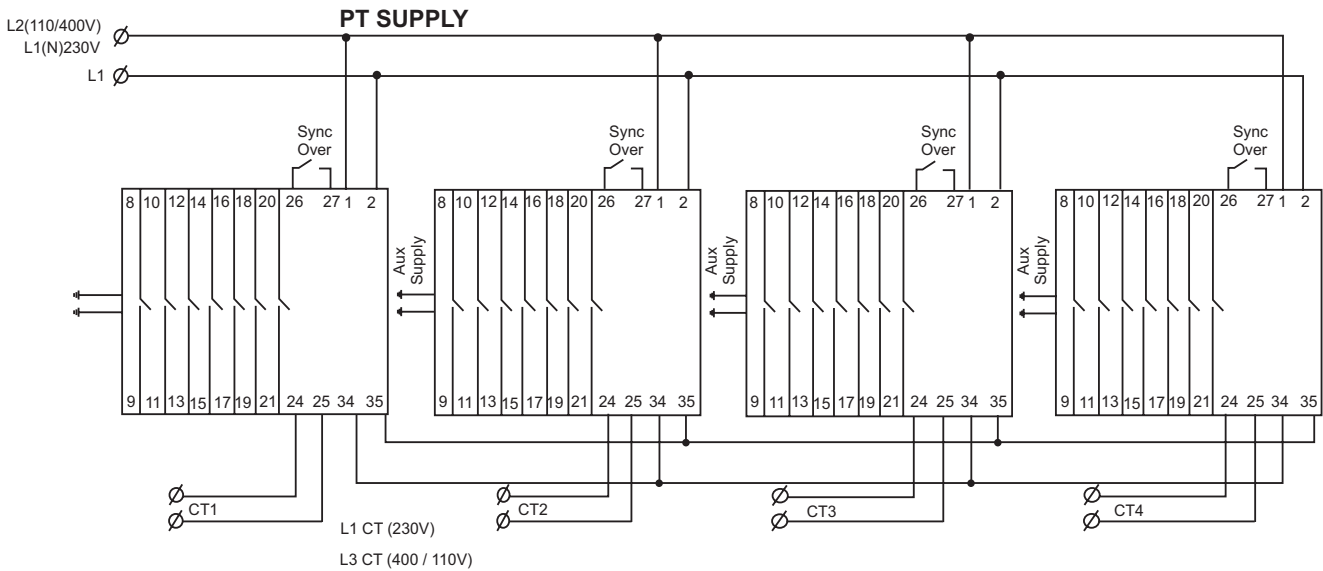

12.4 Dimensions

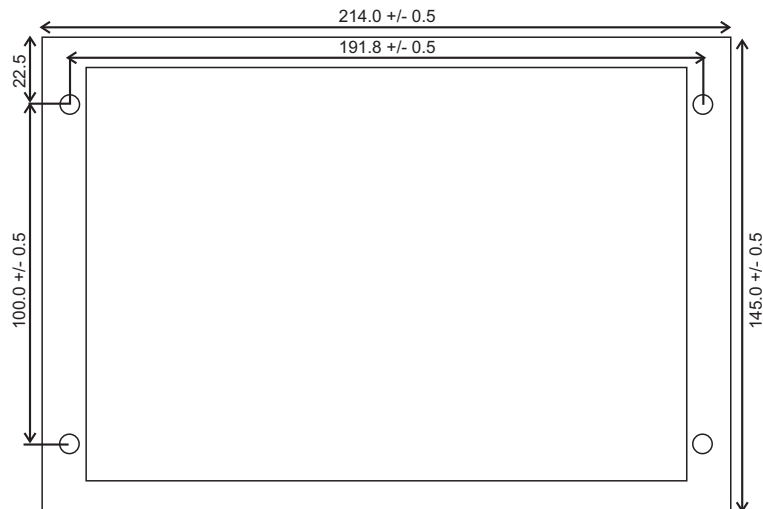

Load Balancing Relay Type : LB-1-FACIA

Panel Cut-out: 182 x144
 Installation Depth : 80
 All dimensions in mm

Technical data subject to change without notice!

13 Order Form

Load Balancing relay	LB1	GOV	AVR		
GOV Control	Relay	R			
	±1 Volts	V1			
	±3 Volts	V3			
	±9 Volts	V9			
	0-5 Volts	V5			
	Current (4-20mA)	C			
AVR Control	Relay		R		
	±1 Volts		V1		
	±3 Volts		V3		
	±9 Volts		V9		
	0-5 Volts		V5		
	Current (4-20mA)		C		
Measuring Voltage AC [V _N]				110V	
				230V	
				400V	
Measuring Current [I _N]					1A
					5A

C&S Electric Limited

(Protection & Control Division)

44, Okhla Industrial Estate, New Delhi -110 020 (INDIA)
 Phone : +91 11- 66602414, 30883745/54/64 Fax: +91 11- 66602413
 E-mail: cspc@cselectric.co.in Web : www.cselectric.co.in

Marketing Offices :

AHMEDABAD: +91 79 30074534/35/36 FAX : +91 79 30074519 **BANGALORE:** +91 80 25586147, 25594939 FAX : +91 25584839
BHUBANESWAR : +91 674 2507265 FAX : +91 674 2507265 **CHANDIGARH :** +91 172 272613, 3062624 FAX : +91 172 2726153
CHENNAI : +91 44 39180531/32/33/34 FAX:+91 44 39180514 **DELHI :** +91 11 30838822-25 Fax:+91 11 30838826 **HYDERABAD :** +91 40 27813003
 FAX : +91 40 27812987 **KOLKATA :** +91 33 22275850/51 FAX : +91 33 22275849 **MUMBAI :** +91 22 24114727/28 FAX : +91 22 24126631
NAGPUR : +91 712 5616651 FAX : +91 712 5616651 **PUNE :** +91 20 30283244/45 FAX : +91 20 30283245 **RAIPUR :** +91 771 320852433/34