

# High-Tech Range

**MRK3** - Time overcurrent relay with auto reclosing relay

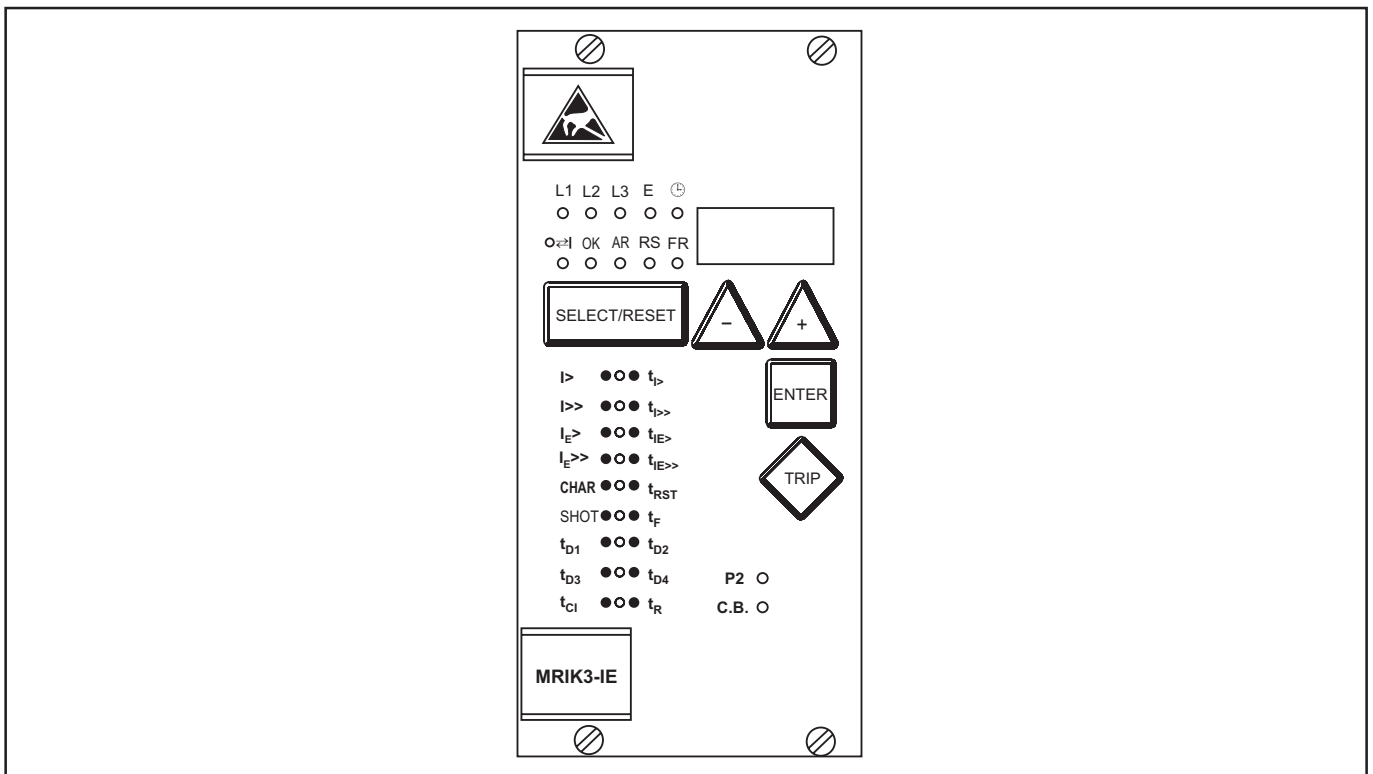

## 1 Introduction and Application

## 2 Features and Characteristics

## 3 Design

### 3.1 Connections

#### 3.1.1 Analog Input circuits

#### 3.1.2 AR Information input circuits

#### 3.1.3 Blocking input

#### 3.1.4 External reset input

#### 3.1.5 Output relays of MARIK3 relays

#### 3.1.6 Fault recorder

### 3.2 LEDs

#### 3.2.1 Indication LEDs

#### 3.2.2 Setting LEDs

### 3.3 Low/High range of signal inputs

## 4 Working Principle

### 4.1 Analog circuits

### 4.2 Digital circuits

### 4.3 Status descriptions

#### 4.3.1 "Inactive"

#### 4.3.2 "Reclaim time" tR

#### 4.3.3 "AR-relay"

#### 4.3.4 "AR-starting" (dead time)

#### 4.3.5 "AR-cycle" (auto reclosing)

#### 4.3.6 "AR-blocked"

#### 4.3.7 "Fast Trip Mode"

#### 4.3.8 Blocking mode

#### 4.3.9 Activating of AR

### 4.4 Description of the status transition

### 4.5 Functional sequence

#### 4.5.1 Switching-on MARIK3

#### 4.5.2 Circuit breaker manual closing

#### 4.5.3 Circuit breaker manual open

#### 4.5.4 Starting AR

#### 4.5.5 Unsuccessful reclosing

#### 4.5.6 Successful reclosing

#### 4.5.7 Repeated reclosing

#### 4.5.8 Supervision of the circuit breaker ready information

#### 4.5.9 External blocking

### 4.6 Time sequence diagrams of MARIK3

4.6.1 The unit is programmed for two shots, successful AR at the second shot

4.6.2 The unit is programmed for two shots, unsuccessful AR

4.6.3 Manual closing of the circuit breaker to faulty lines

4.6.4 Unsuccessful AR

## 5 Operation and settings

### 5.1 Display

### 5.2 Setting Procedure

### 5.3 System parameter

5.3.1 Display of measuring values as primary quantities ( $I_{\text{prim}}$  phase)

5.3.2 Display of earth current as primary quantity ( $I_{\text{prim}}$  earth)

5.3.3 Normal frequency

5.3.4 Display of the activation storage (FLSH/NOFL)

5.3.5 Parameterswitch/external triggering of the fault recorder

### 5.4 Parameter Protection

5.4.1 Pickup current for phase overcurrent element ( $I_{>}$ )

5.4.2 Time current characteristics for phase overcurrent element ( $I_{>} + \text{CHAR}$ )

5.4.3 Trip delay or time multiplier for phase overcurrent element ( $t_{I_{>}}$ )

5.4.4 Reset setting for inverse time tripping characteristics in the phase current path

5.4.5 Current setting for high set element ( $I_{>>}$ )

5.4.6 Trip delay for high set element ( $t_{I_{>>}}$ )

5.4.7 Pickup current for earth fault element ( $t_{E>}$ )

5.4.8 WARN/TRIP changeover

5.4.9 Time current characteristics for earth fault element ( $\text{CHAR } I_E$ )

5.4.10 Trip delay or time multiplier for earth fault element ( $t_{E>>}$ )

5.4.11 Current setting for high set element of earth fault supervision ( $I_{E>>}$ )

5.4.12 Trip delay for high set element of earth fault supervision ( $t_{IE>>}$ )

5.4.13 Parameters auto reclosing Number of AR-SHOTS

5.4.14 Fault time ( $t_F$ )

5.4.15 Dead time ( $t_D$ )

5.4.16 Close impulse time ( $t_{Cl}$ )

- 5.4.17 Reclaim time ( $t_R$ )
- 5.4.18 Fault time activation
- 5.4.19 Block/Trip - time
- 5.4.20 Circuit breaker failure protection  $t_{CBFP}$
- 5.4.21 Adjustment of the slave address
- 5.4.22 Setting of Baud-rate (applies for Modbus protocol only)
- 5.4.23 Setting of parity (applies for Modbus protocol only)
- 5.5 Fault recorder
  - 5.5.1 Number of the fault recordings
  - 5.5.2 Adjustment of trigger occurrences
  - 5.5.3 Pre-trigger time ( $T_{pre}$ )
- 5.6 Adjustment of the clock
- 5.7 Additional functions
  - 5.7.1 Blocking the protection functions, assignment of the output relays and AR-functions
- 5.8 Indication of measuring and fault values
  - 5.8.1 Indication of measuring values
  - 5.8.2 Unit of the measuring values displayed
  - 5.8.3 Indication of fault data
- 5.9 Fault memory
- 5.10 Reset
  - 5.10.1 Erasure of fault storage

## 6 Relay testing and commissioning

- 6.1 Power On
- 6.2 Testing the output relays and LEDs
- 6.3 Checking the set values
- 6.4 Secondary injection test
  - 6.4.1 Test equipment

- 6.4.2 Example of test circuit for MRIK3 relays
- 6.4.3 Checking the input circuits and measured values
- 6.4.4 Checking the operating and resetting values of the relay
- 6.4.5 Checking the relay operating time
- 6.4.6 Checking the high set element of the relay
- 6.4.7 Checking the auto reclosing function
- 6.4.8 Checking the circuit breaker position (A2/A7 and A2/A5)
- 6.4.9 Checking the AR-blocking input (A2/A3)
- 6.4.10 Checking the external blocking and reset functions
- 6.4.11 Testing the external blocking with Block/Trip function
- 6.4.12 Test of the CB failure protection
- 6.5 Primary injection test
- 6.6 Maintenance

## 7 Technical Data

- 7.1 Measuring input circuits
- 7.2 Common data
- 7.3 Setting ranges and steps
  - 7.3.1 Time overcurrent protection
  - 7.3.2 Earth fault protection
  - 7.3.3 Inverse time overcurrent protection relay
  - 7.3.4 Inverse time characteristics
- 7.4 Parameter
- 7.5 Design standard

## 8 Order form

## 1 Introduction and Application

The *MR1K1* digital multifunctional relay is a universal time overcurrent and earth fault protection device with integrated auto reclosing relay intended for use in medium-voltage systems, either with an isolated/compensated neutral point or for networks with a solidly earthed/resistance-earthed neutral point.

In transmission line networks more than 70% of the occurring faults are transient (electric arcs extinguish, branches are falling on the overhead lines etc.)

With the application of the automatic reclosing (AR) together with protection relays, many electric arcs are extinguished through temporary interruption of the energy supply.

Without utilizing the automatic reclosing (AR) power supply interruptions would occur quite frequently.

Statistics have shown that yet part of the faults remain after the first fast AR can be cleared with a longer 2nd AR interval.

The digital multi-shot, three phase auto reclosing relay *MR1K3* fulfills these requirements for use on medium voltage transmission or distribution systems, by 4-element AR with variable adjustable dead times.

## 2 Characteristics and Features

- Digital filtering of the measured values by using discrete Fourier analysis to suppress the high frequency harmonics and DC components induced by faults or system operations,
- two parameter sets,
- selectable protective functions between:  
definite time overcurrent relay or  
inverse time overcurrent relay,
- selectable inverse time characteristics according to IEC 255-4:  
Normal Inverse (Type A)  
Very Inverse (Type B)  
Extremely Inverse (Type C)  
Special characteristics,

- reset setting for inverse time characteristics selectable,
- high set overcurrent unit with instantaneous or definite time function,
- two-element (low and high set) overcurrent relay for both phase and earth faults independent from each other,
- circuit breaker failure protection,
- 4-element AR with Fast-Trip Mode,
- adjustable timer for fault time, dead time, close impulse time and reclaim time,
- external blocking and blocking release of AR,
- optical indications of the AR functional sequence and the AR results,
- external control through optically isolated inputs,
- number of auto reclosings, adjustable from 1 to 4,
- display of measuring values as primary quantities,
- blocking e.g. of high set element (e.g. for selective fault detection through minor overcurrent protection units after unsuccessful AR),
- free assignment of output relays,
- free assignment of protective function for every reclosing separately adjustable,
- blocking the protection function or Fast-Trip-tripping for a selective switch off before and after each AR separately adjustable,
- suppression of indication after an activation (LED flash),
- storage of trip values and switching-off time ( $t_{CBFP}$ ) of 5 fault occurrences (fail-safe of voltage),
- recording of up to eight fault occurrences with time stamp,
- serial data exchange via RS485 interface possible; alternatively with CSE RS485 Pro-Open Data Protocol or Modbus Protocol,
- display of date and time

### Important :

For additional common data of all MR-relays please refer to manual "MR-Digital Multifunctional relays".

### 3 Design

#### 3.1 Connections

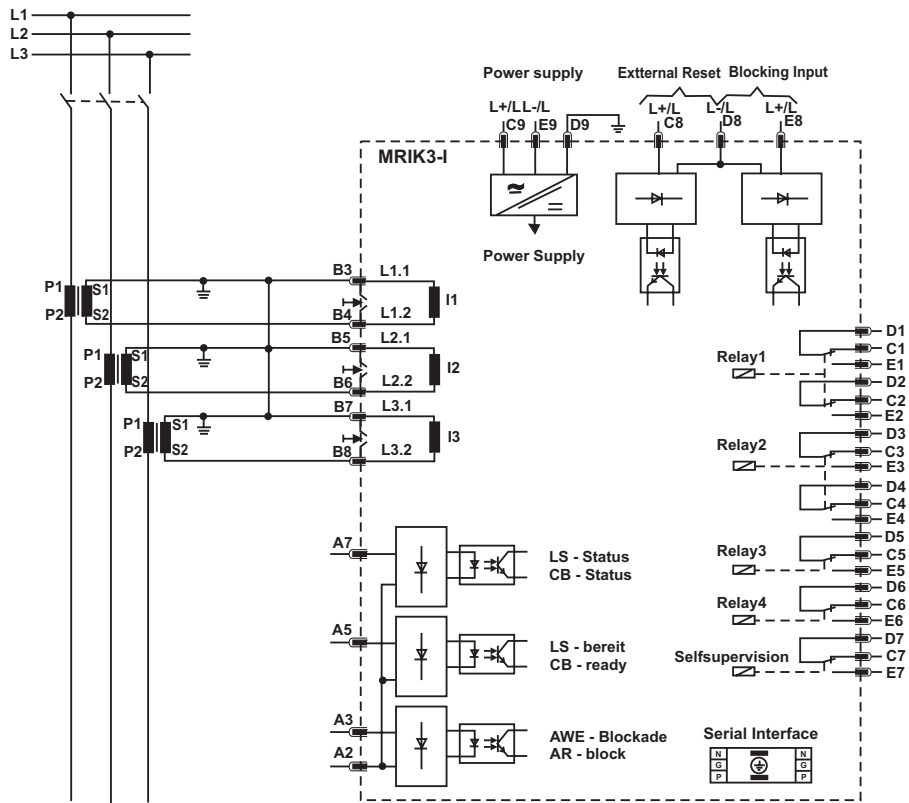

Figure 3.1 : Connections MARIK3-I

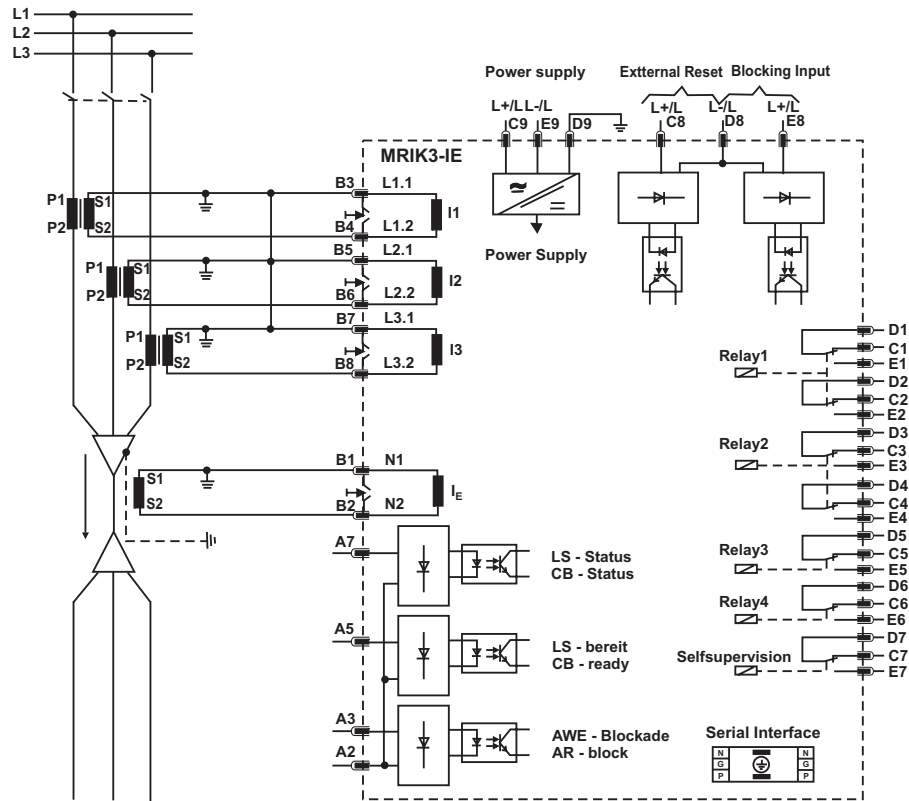

Figure 3.2 : Connections MARIK3-IE

### 3.1.1 Analog input circuits

The protection unit receives the analog input signals of the phase currents IL1 (B3-B4), IL2 (B5-B6), IL3 B7-B8) and the current IE (B1-B2), each via separate input transformers.

The constantly detected current measuring values are galvanically decoupled, filtered and finally fed to the analog/digital converter.

### 3.1.2 AR Information input circuits

With the aid of information inputs unit MARIK3 decides whether and when auto-reclosing may take place:

#### Circuit breaker position (A7)

With input A7 the position of C.B. can be supervised. When the circuit breaker is closed the auxiliary voltage is connected to input A7.

#### Circuit breaker energy (e.g. motor-wound springclosed breakers) (A5)

Because the circuit breaker needs a certain time between two reclosing-attempts in order to close again, the ready signal of the C.B. (auxiliary voltage at A5) is checked before a new auto reclosing takes place. (see also para. 4.5.8)

#### External blocking input (A3)

The unit is blocked when applying voltage to A3.

#### Common point of the inputs (A2)

All listed inputs have a common connection point for L- or N.

### 3.1.3 Blocking input

The protection functions adjusted before will be blocked if an auxiliary voltage is applied to (terminals) D8/E8 (refer to chapter 5.7.1).

### 3.1.4 External reset input

Please refer to chapter 5.10.

### 3.1.5 Output relays of MARIK3 relays

Two relays are equipped with two change-over contacts and three relays with each one change-over contact for alarm. Apart from the relay for self-supervision, all protective functions can be optionally assigned:

- Relay 1: C1, D1, E1 and C2, D2, E2
- Relay 2: C3, D3, E3 and C4, D4, E4
- Relay 3: C5, D5, E5
- Relay 4: C6, D6, E6
- Relay 5: Self-supervision C7, D7, E7

All trip and alarm relays are working current relays, the relay for self supervision is an idle current relay.

The output relays can be assigned to the tripping functions as required.

### 3.1.6 Fault recorder

The MARIK3 has a fault value recorder which records the measured analog values as instantaneous values.

The instantaneous values

$$i_{L1}, i_{L2}, i_{L3}, i_{E}, (i_{Ue})^*,$$

are scanned at a raster of 1.25 ms (at 50 Hz) and 1.041 ms (at 60 Hz) and saved in a cyclic buffer. It is possible to store 1 - 8 fault occurrences with a total recording time of 16 s (with 50 Hz) and 13.33 s (with 60 Hz) per channel. (see chapter 5.5.1)

#### Storage division

Independent of the recording time, the entire storage capacity can be divided into several cases of disturbance with a shorter recording time each. In addition, the deletion behaviour of the fault recorder can be influenced.

#### No writing over

If 2, 4 or 8 recordings are chosen, the complete memory is divided into the relevant number of partial segments. If this max. number of fault event has been exceeded, the fault recorder block any further recordings in order to prevent that the stored data are written over. After the data have been read and deleted, the recorder to ready again for further action.

#### Writing over

If 1, 3 or 7 recordings are chosen, the relevant number of partial segments is reserved in the complete memory. If the memory is full, a new recording will always write over the oldest one.

The memory part of the fault recorder is designed as circulating storage. In this example 7 fault records can be stored (written over).

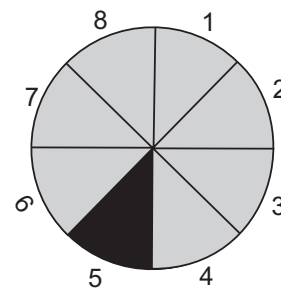

Fig. 3.3 : Division of the memory into 8 segments, for example

Memory space 6 to 4 is occupied.

Memory space 5 is currently being written in

Since memory spaces 6, 7 and 8 are occupied, this example shows that the memory has been assigned more than eight recordings. This means that No. 6 is the oldest fault recording and No. 4 the most recent one.

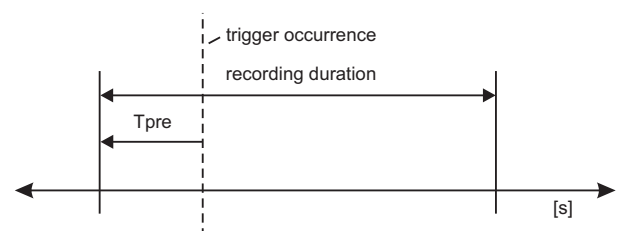

Fig. 3.4 : Basic set-up of the fault recorder

Each memory segment has a specified storage time which permits setting of a time prior to the trigger event.

Via the interface RS485 the data can be read and processed by means of a PC with HTL/PL-Soft 4. The data is graphically edited and displayed. Binary tracks are recorded as well, e.g. activation and trip.

### 3.2 LEDs

Five pushbuttons for control and/or adjustment and up to 21 LEDs are on the front plate of unit MRIK3. The LEDs on the left side of the display indicate the status, fault messages and AR- results. The function of the respective LED is indicated by the legend above the LED.

The LEDs on the left side beneath the <SELECT/RESET> pushbutton are provided for adjustments, their functions are shown with a legend on the right or left side of the LED.

#### 3.2.1 Indication-LEDs

L1, L2, L3, E: Phase or earth current

O→ : green: AR successful; red: AR unsuccessful

OK : AR ready (Does not light: AR inactive)

AR : AR status

CB : Circuit breaker on

RS : Setting slave address

#### 3.2.2 Setting-LEDs

P2 : Two parameter sets

I> : green, pickup value phase current

tl> : red, trip delay / time multiplier phase current

I>> : green pickup value phase current

tl>> : red, trip delay phase current

IE> : green, pickup value earth current

tlIE> : red, trip delay / time multiplier earth current

IE>> : green, pickup value earth current

tlIE>> : red, trip delay earth current

CHAR : green, tripping characteristic phase and earth path

tRST : red, reset time phase and earth

SHOT : green, number of the reclosing attempts

t<sub>F</sub> : red, Fault time

t<sub>D1</sub> : green, Dead time for the first reclosing attempt

t<sub>D2</sub> : red, Dead time for the second reclosing attempt

t<sub>D3</sub> : green, Dead time for the third reclosing attempt

t<sub>D4</sub> : red, Dead time for the fourth reclosing attempt

t<sub>C1</sub> : green, Close impulse time

t<sub>R</sub> : red, Reclaim time

C.B. : Time delay of circuit breaker failure protection

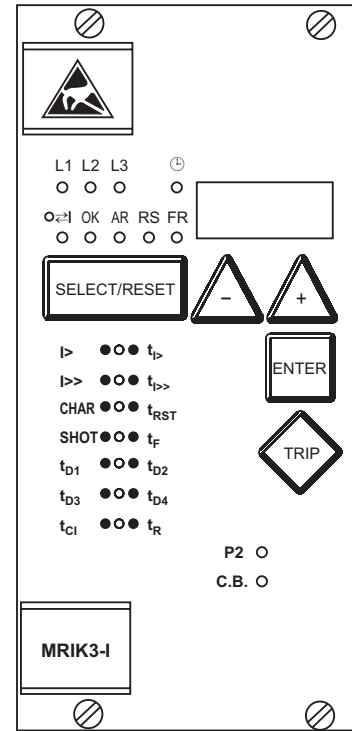

Fig. 3.5 : Front panel MRIK3-I

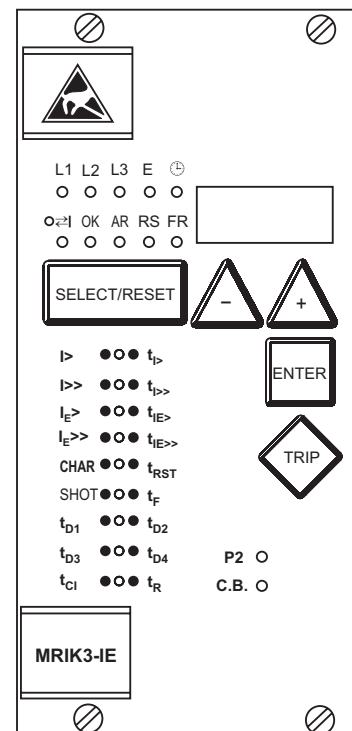

Fig. 3.6 : Front panel MRIK3-IE

### 3.3 Low/High range of signal inputs

The MARIK3 has a wide-range power supply unit allowing to choose a suitable supply voltage. The operating threshold of the signal inputs, however, has to be defined by taking the supply voltage into account. The following two different operating thresholds can be adjusted :

- Low-range threshold  $U_{AN} \geq 10V$ ;  $U_{AB} \leq 8 V$  (code jumper plugged)
- High-range threshold  $U_{AN} \geq 70 V$ ;  $U_{AB} \leq 60 V$  (code jumper not plugged)

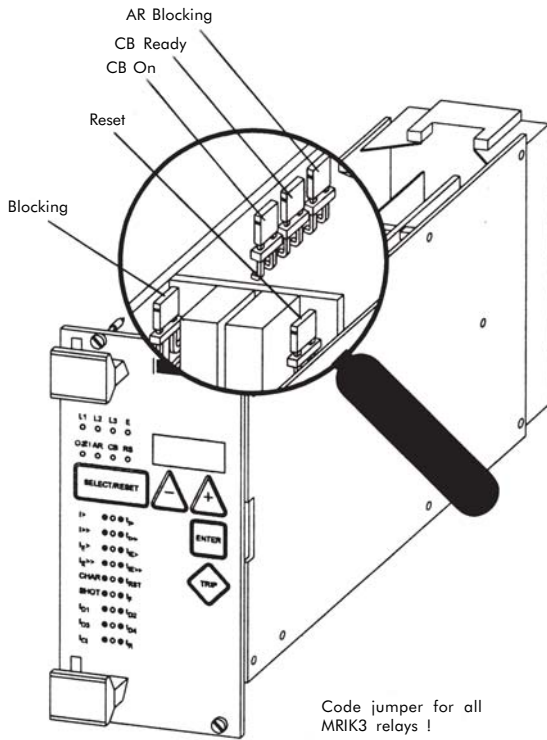

Fig. : 3.7 : Code jumper for MARIK3 relays

## 4 Working principle

### 4.1 Analog circuits

The incoming currents from the main current transformers on the protected object are converted to voltage signals in proportion to the currents via the input transformers and burden. The noise signals caused by inductive and capacitive coupling are suppressed by an analog R-C filter circuit.

The analog voltage signals are fed to the A/D-converter of the microprocessor and transformed to digital signals through Sample- and Hold-circuits. The analog signals are sampled at 50 Hz (60 Hz) with a sampling frequency of 800 Hz (960 Hz), namely, a sampling rate of 1.25 ms (1.04 ms) for every measuring quantity. (16 scans per periode).

### 4.2 Digital circuits

The essential part of the MARIK3 relay is a powerful microcontroller. All of the operations, from the analog digital conversion to the relay trip decision, are carried out by the microcontroller digitally. The relay program is located in an EPROM (Electrically-Programmable-Read-Only-Memory). With this program the CPU of the microcontroller calculates the three phase currents and ground current in order to detect a possible fault situation in the protected object.

For the calculation of the current value an efficient digital filter based on the Fourier Transformation (DFFT - Discrete Fast Fourier Transformation) is applied to suppress high frequency harmonics and DC components caused by fault-induced transients or other system disturbances.

The calculated actual current values are compared with the relay settings. If a phase current exceeds the pickup value, an alarm is given and after the set trip delay has elapsed, the corresponding trip relay is activated.

The relay setting values for all parameters are stored in a parameter memory (EEPROM - Electrically Erasable Programmable Read-only Memory), so that the actual relay settings cannot be lost, even if the power supply is interrupted.

The microprocessor is supervised by a built-in "watchdog" timer. In case of a failure the watchdog timer resets the microprocessor and gives an alarm signal, via the output relay "self supervision".

### 4.3 Status descriptions

Reaction to protection events is possible at any time unless blocking is expressly desired (refer to 3.1.3). In the inactive and blocked state auto reclosing is not possible.

For the explanation of the functional sequence the following six status transitions are defined.

#### 4.3.1 "Inactive"

The relay is in "inactive" status if one of the following conditions is fulfilled:

- The circuit breaker is in position "OFF",
- the unit is in "blocked" status,
- the unit is not in "starting/cycle" status

#### 4.3.2 "Reclaim time" tR

The relay is in "reclaim time" status (tR) when the reclaim time

- has not yet expired or
- not interrupted by other incidents.

### **4.3.3 "AR-ready"**

The relay is in position "AR-ready" status when the following conditions are fulfilled:

- The circuit breaker is in position "ON",
- the reclaim time has expired,
- the unit is not in "blocked" status,
- the unit is not in "starting cycle" status.

Only in "AR-ready" status a reaction of the AR-unit to the protection incidents is possible!

### **4.3.4 "AR-starting" (dead time)**

In "AR-starting" status the start conditions for an automatic reclosing by means of the protection commands and the circuit breaker position are checked.

### **4.3.5 "AR-cycle" (auto reclosing)**

The reclosing commands are carried out in "AR-cycle" status by means of the conditions and the presetting. The results (AR successful or unsuccessful) are evaluated accordingly.

### **4.3.6 "AR-blocked"**

Unit MARIK3 changes immediately to "AR-blocked" status when an external or internal blocking signal (A2-A3) exists. No auto reclosing is possible in "AR-blocked" status.

### **4.3.7 "Fast Trip Mode"**

By way of the function "Assignment of the AR functions" it is possible to activate or deactivate a Fast Trip function for each AR stage and for each protective function. This is applicable for tripping after the last AR.

### **4.3.8 Blocking mode**

By way of the function "Assignment of the AR functions" it is possible to activate or deactivate a protection function for each AR stage. This is applicable for tripping before the 1<sup>st</sup> AR up to tripping after the last AR.

### **4.3.9 "Activating of AR"**

Prior to every AR it is possible to stipulate which kind of tripping ( $I >$  or  $I >>$ , etc.) will lead to automatic reclosing. This can be separately fixed for each AR stage.

## 4.4 Description of the status transition

AR-status transition matrix

to from	inactive	reclaim time	ready	starting (dead time)	cycle (auto reclosing)	blocked
inactive		C.B. manual ON				external blocking signal
reclaim time			reclaim time expired			external blocking signal
ready	C.B. OFF			protection energized and/or tripped and C.B. energy OK		external blocking signal
starting		starting conditions not fulfilled	start signal interrupted		start conditions fulfilled (fault time, C.B. OFF etc.)	external blocking signal
cycle			AR takes place			external or internal blocking signal
blocked	external reset of blocking					

Table 4.1 :   No status transition possible

From Table 4.1 you can detect what status transitions of MARIK3 are possible. When the unit is for instance in "cycle" status (see also para 4.3) only two status transitions are possible :

- status transition to "ready" -status when the auto reclosing takes place
- status transition to "blocked" status by external or internal blocking.

The grey shaded sections indicate that no transition is possible.

## 4.5 Functional sequence

### 4.5.1 Switching-on MARIK3

Is the C.B. to be supervised in OFF position while "switching ON" the MARIK3, the unit changes into "inactive" status when applying the auxiliary voltage. The LED "CB" on the front plate remains dark. The unit is not ready for auto reclosing. If, however, the C.B. is in "ON" position when applying the auxiliary voltage, the unit changes into "reclaim time"-status and remains blocked during this period (from 1 s to 300 s adjustable). This is indicated at the unit by LED  $t_R$ . After expiration of the reclaim time the unit changes to "ready" status and is then ready for auto reclosing. LED "CB" signals this status.

In case unit MARIK3 is in "blocked" status before auxiliary voltage failure occurred, this condition remains also after recurrence of auxiliary voltage.

The LED CB shows the position of the C.B.

### 4.5.2 Circuit breaker manual closing

If the circuit breaker is closed manually to a faultless line, first the unit remains blocked during the reclaim time (adjustable 1 - 300 s) and then changes to "ready" status. If the circuit breaker is closed manually to a faulty line (e.g. short circuit), no AR follows. Unit MARIK3 remains in "inactive" status after protection tripping. This is indicated on the display by „MANU“.

### 4.5.3 Circuit breaker manual open

When switching off the circuit breaker manually the unit changes at once without time delay from "ready" status into "inactive" status. Auto reclosing is not possible. The LED CB extinguishes.

### 4.5.4 Starting AR

When the information "protection energized" and "protection tripping" is applied, the unit changes from "ready" status to "starting" status. The LED "AR" lights up. The "starting" status begins with the start of a fault timer ( $t_F$  from 0.1 s to 2.0 s adjustable). The LED  $t_F$  lights up red. A tripping timer (set at 0.2 s) is started when the mains protection tripping command takes place before expiration of the set fault time. (C.B. must be tripped within this time). The "start conditions not fulfilled" is evaluated and the MARIK3 is locked for the duration of the reclaim time when there is a time difference between mains protection-energized and tripping, which is larger than the set "fault time". The LED  $t_F$  flashes red. If the OFF-signal of the C.B. appears before expiration of the

tripping timer, it is evaluated as "start condition fulfilled" and the unit changes over to "cycle" status. The LED tF extinguishes. If the OFF-signal does not appear, however, before expiration of the tripping timer, it will be evaluated as "start condition not fulfilled" and the unit changes to „inactive" status. The LED CB flashes and the Display shows „CB??".

Tripping timer: Time from the beginning of the tripping command until receiving of the C.B. check-back signal.

#### 4.5.5 Unsuccessful reclosing

After the start condition has been fulfilled the unit changes to "starting" status. Now the dead time tD is started. The corresponding LED flashes. Unit MRK3 can be programmed for reclosing of one to four times. For each reclosing a dead time has to be set (t<sub>D1</sub> to t<sub>D4</sub>). When the dead time has expired and also the other reclosing conditions have been fulfilled, the reclosing command is given to the circuit breaker. The reclosing command remains either as long as the ON-signal from the circuit breaker appears or the close-impuls-timer (t<sub>CL</sub>) has expired.

The LED t<sub>CL</sub> lights up for the duration of the close impulse. When the CB-ON message occurs, the LED t<sub>CL</sub> extinguishes. After expiration of the ON impulse timer the LED starts flashing and the display shows "CB??"

In the last case a failure of the circuit breaker is subjected. With the beginning of the reclosing command the reclaim timer is started. When a new "OFF-signal" of the circuit breaker appears within the reclaim time and after the last permissible AR, an unsuccessful reclosing will be detected. The LED 0→I lights up red and the display shows „OPEN". Then the unit quits the "cycle" status and changes to the "inactive" status. Simultaneously a relay can be activated which indicates unsuccessful auto reclosing.

#### 4.5.6 Successful reclosing

If there is no "OFF-signal" of the circuit breaker and no protection tripping within the reclaim time a successful reclosing will be detected. During the reclaim time the display shows „CLOS" and the LED 0→I lights up green. The unit now quits the "cycle" status, changes over into the "ready" status and is ready for the next reclosing. The LED AR extinguishes and the CB LED lights up. The display shows „CSE".

#### 4.5.7 Repeated reclosing

Is the MRK3 programmed for more than single reclosing a further dead time is started after a new "OFFsignal" from the circuit breaker has appeared. After expiration of this dead time a new reclosing command follows.

#### 4.5.8 Supervision of the circuit breaker ready information

Because the supervising unit of the circuit breaker energy store operates often after the first fast switch off (see also para. 3.1.2), the signal "C.B. not AR-relay" is not evaluated anymore after an introduced reclosing. The C.B. ready information is checked before an introduced AR for further ARs. There will be a reclosing when the

"circuit breaker ready" had been given before the begin of the reclosing cycle. If not, the LED CB flashes and the display shows "S/E?".

#### 4.5.9 External blocking

The AR-relay is blocked if the external AR-block input is activated.

When the reclosing shot is set to "EXIT", the MRK3 can also be blocked at site. (see chapter 5.4.13)

#### 4.6 Time sequence diagrams of MRK3

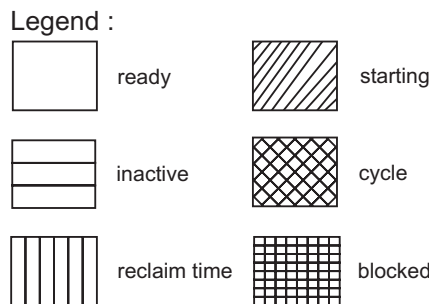

#### 4.6.1 The unit is programmed for two shots, successful AR at the second shot

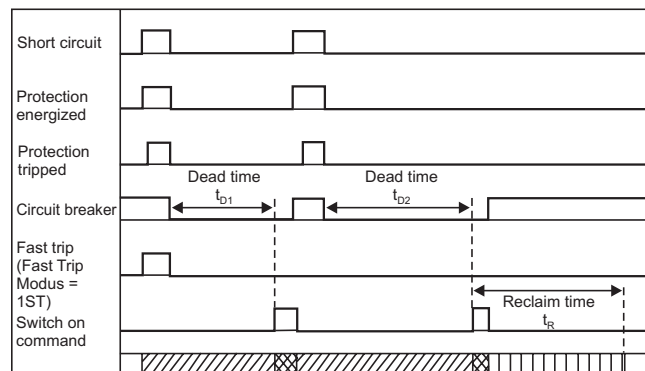

Fig. 4.1 : Two shots, second AR successful

In case of a short circuit an energizing follows with subsequent tripping of the protection relay. The circuit breaker is switched off and the short circuit is cleared. After expiration of the dead time t<sub>D1</sub> unit MRK3 gives the reclosing command to the circuit breaker.

If the fault still exists the protection relay trips again and the above mentioned procedure is repeated as long until either the fault was removed (here after the second reclosing) or the number of the set SHOTs is reached.

### 4.6.2 The unit is programmed for two shots, unsuccessful AR

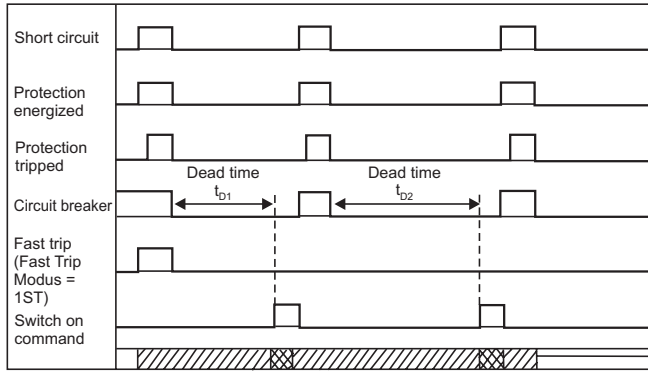

Fig. 4.2 : Two shots, AR unsuccessful

Here the time sequence as described in para 4.6.1. The second reclosing shot is however unsuccessful.

### 4.6.3 Manual closing of the circuit breaker to faulty lines

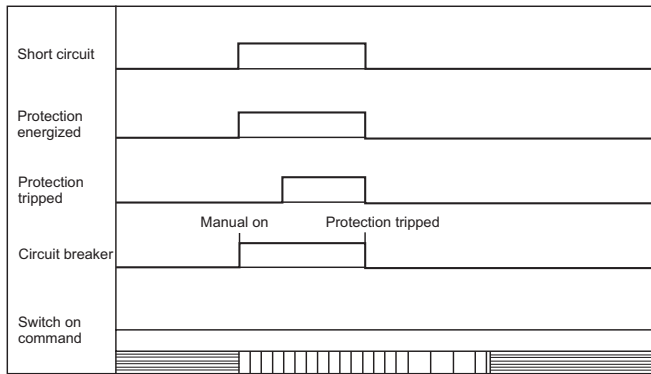

Fig. 4.3 : Manual closing of the C.B. to faulty lines

Unit MARIK3 is in "inactive" status when the circuit breaker is switched off. When the C.B. is manually closed the reclaim time is started. In case there is a faulty line the C.B. is switched off by mains protection of the relay. After elapse of the reclaim time unit MARIK3 changes over to "inactive" status.

### 4.6.4 Unsuccessful AR

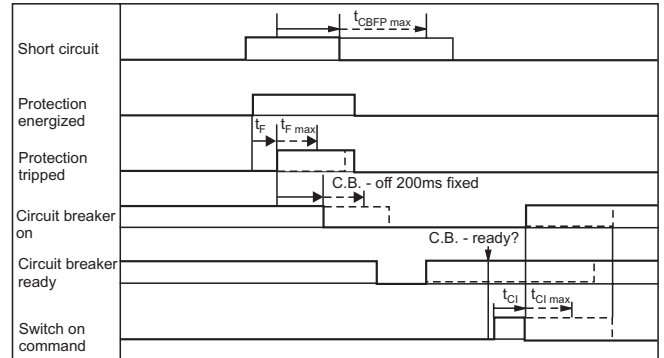

Fig. 4.4 : Unsuccessful AR

The sequence diagram illustrates the various possibilities of an unsuccessful AR.

## 5 Operations and settings

### 5.1 Display

Function	Display shows	Pressed push button	Corresponding LED
Normal operation	CSE		
Measured operating values	Actual measured values	<SELECT/RESET> one time for each value	L1, L2, L3, E
Measuring range overflow	Max.	<SELECT/RESET>	L1, L2, L3, E
Setting values : Phase (I>; CHAR I>; tI>; I>>; tI>>) Earth (IE>; CHAR I <sub>E</sub> >; t <sub>IE</sub> >; I <sub>E</sub> >>; t <sub>IE</sub> >>)	Current settings Trip delay Characteristics	<SELECT/RESET> one time for each parameter	I>; CHAR I>; t <sub>I</sub> >; I>>; t <sub>I</sub> >> I <sub>E</sub> >; CHAR I <sub>E</sub> >; t <sub>IE</sub> >; I <sub>E</sub> >>; t <sub>IE</sub> >>
Parameter switch / external triggering of the fault recorder	SET1, SET2, B_S2, R_S2, B_FR, R_FR, S2_FR	<+> <-> <SELECT/RESET>	P2
Switchable LED-Flash None LED-Flash	FLSH NOFL	<SELECT/RESET> <+> <->	
Characteristics	DEFT, NINV, VINV, EINV, LINV, RINV	<+> <-> <SELECT/RESET>	CHAR I>
Characteristic	DEFT, NINV, VINV, EINV, LINV, RINV, RXIDG	<+> <-> <SELECT/RESET>	CHAR IE>
Reset setting (only available for inverse time characteristics)	0 s / 60 s	<SELECT/RESET> <+> <->	I> + tRST I <sub>E</sub> > + tRST
Warning or tripping at earth fault measuring	trip/warn	<SELECT/RESET> <+> <->	I <sub>E</sub> >
Setting values AWE: Number of auto reclosing attempts Fault time Dead time for 1-4 auto reclosing attempt Close impulse time Fault time activation Reclaim time Fast trip mode	setting value in seconds setting value in seconds setting value in seconds 1 ST / ALL setting value in seconds 1 ST / LAST / EXIT	<SELECT/RESET> <+> <-> one time for each value	SHOT t <sub>E</sub> red t <sub>D1</sub> , t <sub>D2</sub> , t <sub>D3</sub> , t <sub>D4</sub> t <sub>C1</sub> green t <sub>I</sub> >; I>; I>>; I <sub>E</sub> >; I <sub>E</sub> >> t <sub>R</sub> red I>> + SHOT
Block / Trip-time	setting value in seconds	<SELECT/RESET><+><->	I>, I>>, t <sub>I</sub> >, t <sub>I</sub> >>, green
Time delay of circuit breaker failure protection t <sub>CBFP</sub>	setting value in seconds	<SELECT/RESET> <+> <->	CB
Blocking of function	EXIT	<+> until max. setting value	LED of blocked parameter
Nominal frequency	f=50 / f=60	<SELECT/RESET><+><->	
Slave address of serial interface	1-32	<SELECT/RESET><+><->	RS
Baud-Rate <sup>1)</sup>	1200-9600	<SELECT/RESET><+><->	RS
Parity-Check <sup>1)</sup>	even odd no	<SELECT/RESET><+><->	RS
Recorded fault data	Tripping currents C.B. tripping time max. pickup time	<SELECT/RESET> one time for each phase, <+><-> for older fault recording	L1, L2, L3, E I>, I>>, I <sub>E</sub> >, I <sub>E</sub> >> CB
Circuit breaker defect	CB??		CB blinking
Auto reclosing successful	CLOS		0→1 green
Auto reclosing unsuccessful	OPEN		0→1 red
Auto reclosing locked-out	BLOCK		
After dead time reclosing condition not fulfilled	S / E?		0→1 red CB blinking
Circuit breaker was manually switched on	MANU		
Circuit breaker failure protection	CBFP		CB blinking
Display if AR is unsuccessful			0→1 red
Trigger signal for the fault recorder	TEST, P_UP, A_PI, TRIP	<SELECT/RESET><+><->	FR
Number fo fault occurrences	S=2, S=4, S=8	<SELECT/RESET><+><->	FR

<sup>1)</sup> only Modbus

Function	Display shows	Pressed push button	Corresponding LED
Display of date and time	Y=99, M=10, D=1, h=12, m=2, s=12	<SELECT/RESET><+><->	☺
Change over the blocking function	PR_B, TR_B	<ENTER> und <TRIP>; <+><->	I>, I>>, I <sub>E</sub> >, I <sub>E</sub> >> oder t <sub>I</sub> >, t <sub>I</sub> >>, t <sub>IE</sub> >, t <sub>IE</sub> >>
Blocking the protection function	BLOC, NO_B	<+><-> <SELECT/RESET>	I>, I>>, IE>, IE>>
AR approved	YES/NO	<+> <-> <SELECT/RESET>	AR + I> AR + I>> AR + I <sub>E</sub> > AR + I <sub>E</sub> >> Running with tD1, tD2, tD3, tD4
Protection steps blocked	BLOC	<+> <-> <SELECT/RESET>	I> I>>
Normal trip time	TIME		IE> IE>>
Fast trip	FAST		Running with tD1, tD2, tD3, tD4
Save parameter?	SAV?	<ENTER>	
Save parameter!	SAV!	<ENTER> for about 3 s	
Software version	First part (e.g. A00-) Sec. part (e.g. 4.01)	<TRIP> one time for each part	
Manual trip	TRI?	<TRIP> 3 times	
Inquire password	PSW?	<SELECT/RESET> <+> <-><ENTER>	
Relay tripped	TRIP	<TRIP> or after fault tripping	
Secret password input	XXXX	<SELECT/RESET> <+> <-><ENTER>	
Switch-over LED flash	FLSH	<SELECT/RESET>	
No LED flash	NOFL	<+> <->	
Enquiry failure memory	FLT1; FLT2....	<+><->	
Delete failure memory	wait	<-><SELECT/RESET>	
System reset	CSE	<SELECT/RESET> for about 3 s	

Table 5.1 : Possible indication message on the display

## 5.2 Setting procedure

After push button <SELECT/RESET> has been pressed, always the next measuring value is indicated. Firstly the operating measuring values are indicated and then the setting parameters. By pressing the <ENTER> push button the setting values can directly be called up and changed.

## 5.3 Systemparameter

### 5.3.1 Display of measuring values as primary quantities ( $I_{prim}$ phase)

With this parameter it is possible to show the indication as primary measuring value. For this purpose the parameter must be set to be equal with the rated primary CT current. If the parameter is set to "sec", the measuring value is shown as a multiple of the rated secondary CT current.

#### Example:

The current transformer used is of 1500/5 A. The flowing current is 1380 A. The parameter is set to 1500 A and on the display "1380 A" are shown. If the parameter is set to "sec", the value shown on the display is "0.92" x In.

#### Note:

The pick-up value is set to a multiple of the rated secondary CT current.

### 5.3.2 Display of earth current as primary quantity ( $I_{prim}$ earth)

The parameter of this function is to be set in the same way as that described under 5.3.1. If the parameter is not set to "sec", to relay types MRI3-X and MRI3-XR it applies too, that the measuring value is shown as primary current in ampere. Apart from that the indication refers to % of  $I_N$ .

### 5.3.3 Nominal frequency

The adapted FFT-algorithm requires the nominal frequency as a parameter for correct digital sampling and filtering of the input currents.

By pressing <SELECT> the display shows "f=50" or "f=60". The desired nominal frequency can be adjusted by <+> or <-> and then stored with <ENTER>.

### 5.3.4 Display of the activation storage (FLSH/NOFL)

If after an activation the existing current drops again below the pickup value, e.g.  $I >$ , without a trip has been initiated, LED  $I >$  signals that an activation has occurred by flashing fast. The LED keeps flashing until it is reset again (push button <RESET>). Flashing can be suppressed when the parameter is set to NOFL.

### 5.3.5 Parameterswitch/external triggering of the fault recorder

By means of the parameter-change-over switches it is possible to activate two different parameter sets. Switching over of the parameter sets can either be done by means of software or via the external inputs RESET or blocking input. Alternatively, the external inputs can be used for Reset or blocking of the triggering of the fault recorder.

Software parameter	Blocking input used as	RESET input used as
SET1	Blocking input	RESET input
SET2	Blocking input	RESET input
B_S2	Parameter switch	RESET input
R_S2	Blocking input	Parameter switch
B_FR	External triggering of the fault recorder	RESET input
R_FR	Blocking input	External triggering of the fault recorder
S2_FR	Parameter switch	External triggering of the fault recorder

With the settings SET1 or SET2 the parameter set is activated by software. Terminals C8/D8 and D8/E8 are then available as external reset input or blocking input.

With the setting B\_S2 the blocking input (D8, E8) is used as parameter-set change-over switch. With the setting R\_S2 the reset input (D8, E8) is used as parameterset change-over switch. With the setting B\_FR the fault recorder is activated immediately by using the blocking input. On the front plate the LED FR will then light up for the duration of the recording. With the setting R\_FR the fault recorder is activated via the reset input. With the setting S2\_FR parameter set 2 can be activated via the blocking input and/or the fault recorder via the reset input.

The relevant function is then activated by applying the auxiliary voltage to one of the external inputs.

### Important note:

When functioning as parameter change over facility, the external input RESET is not available for resetting. When using the external input BLOCKING the protection functions must be deactivated by software blocking separately (refer to chapter 5.7.1).

## 5.4 Parameter protection

### 5.4.1 Pickup current for phase overcurrent element (I>)

The setting value for this parameter that appears on the display is related to the nominal current ( $I_N$ ) of the relay. This means: pickup current ( $I_s$ ) = displayed value x nominal current ( $I_N$ ) e.g. displayed value = 1.25 then,  $I_s = 1.25 \times I_N$ .

### 5.4.2 Time current characteristics for phase overcurrent element (I> + CHAR)

By setting this parameter, one of the following 6 messages appears on the display:

- DEFT - Definite Time (Type A)
- NINV - Normal Inverse (Type B)
- VINV - Very Inverse (Type C)
- EINV - Extremely Inverse
- LINV - Long Time Inverse
- RINV - RI - Inverse

Anyone of these four characteristics can be chosen by using <+> <->-push buttons, and can be stored by using <ENTER>-push button.

### 5.4.3 Trip delay or time multiplier for phase overcurrent element (tl>)

Usually, after the tripping characteristic is changed, the time delay or the time multiplier should be changed accordingly. In order to avoid an unsuitable arrangement of relay modes due to carelessness of the operator, the following precautions are taken:

After the change of the characteristic setting, the setting process turns to the time delay setting automatically. The LED tl> is going to flash yellow to remind the operator to change the time delay setting accordingly. After pressing the <SELECT>-push button, the present time delay setting value is shown on the display. The new setting value can then be changed by using <+> <-> -push buttons.

If, through a new setting, another relay characteristic other than the old one has been chosen (e.g. from DEFT to NINV), but the time delay setting has not been changed despite the warning from the flashing LED, the relay will be set to the most sensitive time setting value of the selected characteristics after five minutes warning of flashing LED tl>. The most sensitive time setting value means the fastest tripping for the selected relay characteristic. When the time delay or the time multiplier is set out of range (Text "EXIT" appears on the display), the low set element of the overcurrent relay is blocked. The "WARN"-relay will not be blocked.

### 5.4.4 Reset setting for inverse time tripping characteristics in the phase current path

To ensure tripping, even with recurring fault pulses shorter than the set trip delay, the reset mode for all tripping characteristics can be switched over. If the adjustment RST is set at 60 s, the tripping time is only reset after 60 s faultless condition. This function is not available if RST is set to 0. With interruption of the fault current the trip delay is reset immediately and started again at recurring fault current.

### 5.4.5 Current setting for high set element (I>>)

The current setting value of this parameter appearing on the display is related to the nominal current of the relay.

This means: I>> = displayed value x  $I_N$ .

When the current setting for high set element is set out of range (on display appears "EXIT"), the high set element of the overcurrent relay is blocked.

The high set element can be blocked via terminals E 8/ D8 if the corresponding blocking parameter is set to BLOC (refer to 5.7.1).

### 5.4.6 Trip delay for high set element (t<sub>I>></sub>)

Independent from the chosen tripping characteristic for I>, the high set element I>> has always a definite-time tripping characteristic. An indication value in seconds appears on the display.

### 5.4.7 Pickup current for earth fault element (I<sub>E></sub>)

Similar to the chapter 5.4.1.

### 5.4.8 WARN/TRIP changeover

A detected earth fault can be parameterized as follows. After delay time

- a) "warn" only the alarm relay trips
- b) "trip" the trip relay trips and tripping values are stored.

### 5.4.9 Time current characteristics for earth fault element (CHAR I<sub>E</sub>)

By setting this parameter, one of the following 7 messages appears on the display:

- DEFT - Definite Time
- NINV - Normal inverse (Type A)
- VINV - Very inverse (Type B)
- EINV - Extremely inverse (Type C)
- RINV - RI-Inverse
- LINV - Long Time Inverse
- RXID - Special characteristic

Anyone of these seven characteristics can be chosen by using <+> <->-push buttons, and can be stored by using <ENTER>-push button.

#### 5.4.10 Trip delay or time multiplier for earth fault element ( $t_{IE>>}$ )

Similar to the chapter 5.4.3.

#### 5.4.11 Current setting for high set element of earth fault supervision ( $I_{E>>}$ )

Similar to the chapter 5.4.5.

#### 5.4.12 Trip delay for high set element of earth fault supervision ( $t_{IE>>}$ )

Similar to the chapter 5.4.6.

#### 5.4.13 Parameters auto reclosing Number of AR-SHOTS

Indicates how often the circuit breaker may switch on again when a fault occurs.

#### 5.4.14 Fault time ( $t_F$ )

Reclosing is permitted during this time. It starts with the energizing of the corresponding protection devices. A reclosing attempt follows only if the command time of the protection devices is shorter than the fault time set at MARIK3.

#### 5.4.15 Dead time ( $t_D$ )

Starts with the OFF-signal of the circuit breaker. No closing command to the circuit breaker is given till expiration of the set dead time.

#### 5.4.16 Close impulse time ( $t_{CI}$ )

During close impulse time  $t_{CI}$  the NO C.B. contact of MARIK3 is closed. It starts with expiration of the dead time and is interrupted earlier when the ON-signal of the circuit breaker is already present before expiration of the time.

#### 5.4.17 Reclaim time ( $t_R$ )

This is the time during which - after switching on (also manually) or after AR - a subsequent reclosing is prevented. If the number of the set shots is reached, the MARIK3 is blocked for this time after the last reclosing attempt.

The reclaim time is started with the automatic closing command or by switching on manually. An OFF command which occurs after the last permissible AR leads to a final switching-off.

#### 5.4.18 Fault time activation

This parameter can be used to fix whether the supervision of the fault time is active for the first tripping action or for all tripping actions (see 5.4.14).

#### 5.4.19 Block/Trip - time

The block/trip time serves for detection of a c.b. failure protection by rear interlocking. It is activated by setting the blocking input D8/E8 and by setting the parameter to TR\_B. After the set block/trip time has expired, the relay can be tripped if the excitation of a protective function has been applied the delay time of which has expired and the blocking function is still active. If the parameter PR\_B is set, the individual protection stages are blocked (refer to Chapter 5.7.1).

#### 5.4.20 Circuit breaker failure protection

$t_{CBFP}$

The C.B. failure protection is based on supervision of the phase currents during tripping of the relay. This protective function becomes only active after tripping and it is then checked whether all phase currents have dropped to 0 within time  $t_{CBFP}$  (Circuit Breaker Failure Protection). Should not all phase currents have dropped within this time ( $t_{CBFP}$  can be adjusted from 0.1 - 2.0 s), the protection device diagnoses C.B. failure and the respective assigned relay is activated. The C.B. failure protection function is deactivated again, when all phase currents drop to 0 within  $t_{CBFP}$ .

#### 5.4.21 Adjustment of the slave address

Pressing push buttons <+> and <-> the slave address can be set in range of 1-32.

#### 5.4.22 Setting of Baud-rate (applies for Modbus Protocol only)

Different transmission rates (Baud rate) can be set for data transmission via Modbus protocol.

The rate can be changed by push buttons <+> and <-> and saved by pressing <ENTER>.

#### 5.4.23 Setting of parity (applies for Modbus Protocol only)

The following three parity settings are possible

- "even" = even
- "odd" = odd
- "no" = no parity check

The setting can be changed by push buttons <+> and <-> and saved by pressing <ENTER>.

### 5.5 Fault recorder

The MARIK3 is equipped with a fault recorder (see chapter 3.7). Three parameters can be determined.

#### 5.5.1 Number of the fault recordings

The number of max. recordings requested has to be determined in advance. There is a choice of (1)\* 2, (3)\* 4 or (7)\* 8 recordings and dependent on this the duration of the individual fault recordings is defined, i.e.

(1)\* 2 recordings for a duration of 8 s (with 50 Hz) (6.66 s with 60 Hz)

(3)\* 4 recordings for a duration of 4 s (with 50 Hz) (3.33 s with 60 Hz)

(7)\* 8 recordings for a duration of 2 s (with 50 Hz) (1.66 s with 60 Hz)

\* is written over when a new trigger signal arrives

## 5.5.2 Adjustment of trigger occurrences

There is a choice between four different occurrences:

P_UP (PickUP)	Storage is initiated after recognition of a general activation.
TRIP	Storage is initiated after a trip has occurred.
A_PI (After Pickup)	Storage is initiated after the last activation threshold was fallen short of.
TEST	Storing is activated by simultaneous actuation of the keys <+> and <->. During the recording time the display shows "Test".

## 5.5.3 Pre-trigger time ( $T_{pre}$ )

By the time  $T_{pre}$  it is determined which period of time prior to the trigger occurrence should be stored as well. It is possible to adjust a time between 0.05 s and 8 s. With keys <+> and <-> the values can be changed and with <ENTER> be saved.

## 5.6 Adjustment of the clock

When adjusting the date and time, LED  $\oplus$  lights up. The adjustment method is as follows:

Date:	Year	Y = 00
	Month	M = 00
	Day	D = 00
Time:	Hour	h = 00
	Minute	m = 00
	Second	s = 00

The clock starts with the set date and time as soon as the supply voltage is switched on. The time is safeguarded against short-term voltage failures (min. 6 minutes).

### Note:

The window for parameter setting is located behind the measured value display. The parameter window can be accessed via the <SELECT/RESET> key.

## 5.7 Additional functions

### 5.7.1 Blocking the protection functions, assignment of the output relays and AR - functions

#### Blocking of the protective functions:

The MRK3 is equipped with a blocking function that can be parameterized arbitrary. Connecting supply voltage to terminals D8/E8 blocking of those functions which were selected by the user takes place.

It is possible to choose between two types of protective blocking:

1. Blocking of the individual protection stages. The excitation of the blocked protection stage is blocked.
2. Blocking of the individual tripping stages. The individual protection stages are excited and the set tripping time expires. Tripping only takes place when:

- a) the voltage at the blocking input D8/E8 is reduced;
- b) the voltage at the blocking input D8/E8 is applied, the tripping time and the blocking time have expired. (refer to Chapter 5.4.16)

Parameter setting is to be carried out as follows:

- After the <ENTER> and <TRIP> keys have been actuated simultaneously, the display shows the text "PR\_B" (the protection stages are blocked) or "TR\_B" (the tripping stages are blocked).
- The settings can be changed by actuating the keys <+> or <->. In this procedure, the LEDs I>; I>>; IE>; IE>> are simultaneously alight in case of protective blocking "PR\_B" and LEDs tI>; tI>>; tIE>; tIE>> simultaneously emit light in case of trip blocking "TR\_B".
- Actuation of the <ENTER> key with a one-time entry of the password will store the set function.
- After this actuate the <SELECT/RESET> key to call up the first blockable protection function.
- The display will show the text "BLOC" (the respective function is blocked) or "NO\_B" (the respective function is not blocked).
- Actuation of the <ENTER> key will store the set function.
- By pressing the <SELECT/RESET> pushbutton, all further protective function that can be blocked are called one after the other.
- After selection of the last blocking function renewed pressing of the <SELECT/RESET> pushbutton switches to the assignment mode of the output relays.

Function		Display	LED/Colour
I>	Overcurrent (Low set)	NO_B	I>green
I>>	Overcurrent (High set)	BLOC	I>>green
IE>	Earth current 1. element	NO_B	IE> green
IE>>	Earth current 2. element	NO_B	IE>> green
CBFP	Circuit breaker failure protection	NO_B	CB yellow

Table 5.2: Default settings for both parameter sets

#### Assignment of the output relays:

Unit MRK3 has five output relays. The fifth output relay, provided as permanent alarm relay for self supervision is normally on. Output relays 1 - 4 are normally off and can be assigned as alarm or tripping relays to the current functions which can either be done by using the push buttons on the front plate or via serial interface RS485. The assignment of the output relays is similar to the setting of parameters, however, only in the assignment mode. The assignment mode can be reached only via the blocking mode.

By pressing push button <SELECT/RESET> in blocking mode again, the assignment mode is selected.

**Definition:**

Alarm relays are activated at pickup.

Tripping relays are only activated after elapse of the tripping delay.

The relays are assigned as follows:

- LEDs I>, I>>, I<sub>E></sub>, I<sub>E>></sub> are two-coloured and light up green when the output relays are assigned as alarm relays and red as tripping relays.
- After the assignment mode has been activated, first LED I> lights up green. Now one or several of the four output relays can be assigned to current element I> as alarm relays. At the same time the selected alarm relays for frequency element 1 are indicated on the display.
- Indication "1 \_ \_ \_" means that output relay 1 is assigned to this current element. When the display shows " \_ \_ \_ \_", no alarm relay is assigned to this current element.
- The assignment of output relays 1 - 4 to the current elements can be changed by pressing <+> and <-> push buttons.

- The selected assignment can be stored by pressing push button <ENTER> and subsequent input of the password.
- By pressing push button <SELECT/RESET>, LED I> lights up red. The output relays can now be assigned to this current element as tripping relays. Relays 1 - 4 are selected in the same way as described before.
- By repeatedly pressing of the <SELECT/RESET> push button and assignment of the relays all elements can be assigned separately to the relays.
- After the last relay assignment, press <SELECT/RESET> once more to move on to the assignment of the AWE functions.

**Note:**

The function of jumper J2 and J3 described in general description "MR Digital Multifunctional Relays" have no function. For relays without assignment mode this jumpers are used for parameter setting of alarm relays (activation at pickup or tripping and manual reset).

Relay functions	Output relays				Display indication	Lighted LED
	1	2	3	4		
I> alarm tripping	X	X			_ 2 _ _ 1 _ _ _	I> : green t : red I>
I>> alarm tripping	X	X			_ 2 _ _ 1 _ _ _	I>> : green t : red I>>
I>> FAST TRIP tripping	X				1 _ _ _	I>/I>> : green + CB green
I <sub>E&gt;</sub> alarm tripping	X	X			_ 2 _ _ 1 _ _ _	I <sub>E&gt;</sub> : green t <sub>E&gt;</sub> : red I <sub>E&gt;</sub>
I <sub>E&gt;&gt;</sub> alarm tripping	X	X			_ 2 _ _ 1 _ _ _	I <sub>E&gt;&gt;</sub> : green t <sub>E&gt;&gt;</sub> : red I <sub>E&gt;&gt;</sub>
CBFP tripping			X		_ _ 3 _	CB green
AWE switch on				X	_ _ _ 4	AR yellow + t <sub>ci</sub> green
AWE Unsuccessful			X		_ _ 3 _	AR yellow + O→I red

Table 5.3 : Example of assignment matrix of the output relay (default settings)

### Assignment of the AR functions

The last activation of the <SELECT/RESET> key in the relay assignment mode will activate the AR assignment mode.

- The accompanied LEDs indicate which functions will be assigned to the individual protection stages for parameter setting before the 1st AR.
- Actuation of the <+> <-> keys permits switching over between "BLOC", "TIME" or "FAST".

Here the following functions are activated or deactivated one after the other.

1. "BLOC" blocking of the protective functions.
  2. "TIME" tripping of the individual protective functions with set delay time.
  3. "FAST" tripping with Fast Trip function.
- Actuation of the <ENTER> key with subsequent onetime entry of the pass word will store the altered value.
  - Actuation of the <SELECT/RESET> key will assign the tripping function before the 1st AR, one after the other to the individual protection stages.
  - After this adjustment the parameters are set for activation of the 1st AR.
  - The accompanied LEDs indicate which protective functions are available for parameter setting for the first AR.
  - Actuation of the <+> <-> keys permits switching over between "YES" and "NO". "YES" means that the selected protection function will trigger an AR.
  - Actuation of the <ENTER> key with subsequent onetime entry of the password will store the altered value.
  - Actuation of the <SELECT/RESET> key the protective functions are, one after the other, assigned to the first AR.

The following table shows all parameters that have to be set. After each group the setting changes between parameter set 1 and 2.

Function	Protection step	Display indication	Corresponding LED
trip before the 1 <sup>st</sup> AR	I>	TIME	I> + tD1
	I>>	TIME	I>> + tD1
	IE>	TIME	IE> + tD1
	IE>>	TIME	IE>> + tD1

Function	Protection step	Display indication	Corresponding LED
Activation Of the 1 <sup>st</sup> 1AR per	I>	NO	AR + I> + tD1
	I>>	YES	AR+I>>+tD1
	IE>	NO	AR+IE>+tD1
	IE>>	NO	AR+EI>>+tD1

Function	Protection step	Display indication	Corresponding LED
trip after the 1 <sup>st</sup> AR	I>	TIME	I> + tD1
	I>>	TIME	I>> + tD1
	IE>	TIME	IE> + tD1
	IE>>	TIME	IE>> + tD1

Function	Protection step	Display indication	Corresponding LED
Activation Of the 2 <sup>nd</sup> AR per	I>	NO	AR + I> + tD2
	I>>	YES	AR+I>>+tD2
	IE>	NO	AR+IE>+tD2
	IE>>	NO	AR+EI>>+tD2

Function	Protection step	Display indication	Corresponding LED
trip after the 2 <sup>nd</sup> AR	I>	TIME	I> +tD2
	I>>	TIME	I>> +tD2
	IE>	TIME	IE> +tD2
	IE>>	TIME	IE>> +tD2

Function	Protection step	Display indication	Corresponding LED
Activation Of the 3 <sup>rd</sup> AR per	I>	NO	AR + I> + tD3
	I>>	YES	AR+I>>+tD3
	IE>	NO	AR+IE>+tD3
	IE>>	NO	AR+EI>>+tD3

Function	Protection step	Display indication	Corresponding LED
trip after the 3 <sup>rd</sup> AR	I>	TIME	I> +tD3
	I>>	TIME	I>> +tD3
	IE>	TIME	IE> +tD3
	IE>>	TIME	IE>> +tD3

Function	Protection step	Display indication	Corresponding LED
Activation Of the 4 <sup>th</sup> 1AR per	I>	NO	AR + I> +tD4
	I>>	YES	AR+I>>+tD4
	IE>	NO	AR+IE>+tD4
	IE>>	NO	AR+EI>>+tD4

Function	Protection step	Display indication	Corresponding LED
trip after the 4 <sup>th</sup> AR	I>	TIME	I> +tD4
	I>>	TIME	I>> +tD4
	IE>	TIME	IE> +tD4
	IE>>	TIME	IE>> +tD4.

Table 5.4 : Assignment of AR functions

The assignment mode can be terminated at any time by pressing the <SELECT/RESET> push button for some time (abt. 3 s).

A form is attached to this description where the setting requested by the customer can be filled-in. This form is prepared for telefax transmission and can be used for your own reference as well as for telephone queries.

## 5.8 Indication of measuring and fault values

### 5.8.1 Indication of measuring values

The following measuring quantities can be indicated on the display during normal service :

- Apparent current in phase 1 (LED L1 green),
- apparent current in phase 2 (LED L2 green),
- apparent current in phase 3 (LED L3 green),
- apparent earth current (LED E green)

### 5.8.2 Unit of the measuring values displayed

The measuring values can optionally be shown in the display as a multiple of the "sec" rated value (x In) or as primary current (A). According to this the units of the display change as follows :

#### Phase current

Indication as	Range	Unit
Secondary current	0.00 - 40.0	x In
Primary current	.000 - 999.	A
	k000 - k999	kA*
	1k00 - 9k99	kA
	10k0 - 99k0	kA
	100k - 999k	kA
	1M00 - 2M00	MA

Table 5.5 : Ranges of phase currents from 2kA prim transformer rated current

#### Earth current

Indication as	Range	Unit
Secondary current	.000 - 15.0	x In
Primary current	.000 - 999.	A
	k000 - k999	kA*
	1k00 - 9k99	kA
	10k0 - 99k0	kA
	100k - 999k	kA
	1M00 - 2M00	MA

Table 5.6 : Ranges of earth currents from 2kA prim transformer rated current

### 5.8.3 Indication of fault data

All faults detected by the relay are indicated on the front plate optically. For this purpose, the four LEDs (L1, L2, L3, E) and the four function LEDs (I>, I>>, IE> and IE>>) are equipped at MRK3. If, for example an overcurrent occurs, first the respective phase LEDs will light up. LED I> lights up at the same time. After tripping the LEDs are lit permanently.

### 5.9 Fault memory

When the relay is energized or trips, all fault data and times are stored in a non-volatile memory. The MRK3 is provided with a fault value recorder for max. 8 fault occurrences. In the event of additional trippings always the oldest data set is written over.

For fault indication not only the trip values are recorded but also the status of LEDs. Fault values are indicated when push buttons <-> or <+> are pressed during normal measuring value indication.

- Normal measuring values are selected by pressing the <SELECT/RESET> button.
- When then the <-> button is pressed, the latest fault data set is shown. By repeated pressing the <-> button the last but one fault data set is shown etc. For indication of fault data sets abbreviations FLT1, FLT2, FLT3, ... are displayed (FLT1 means the latest fault data set recorded). At the same time the parameter set active at the occurrence is shown.
- By pressing <SELECT/RESET> the fault measuring values can be scrolled.
- By pressing <+> it can be scrolled back to a more recent fault data set. At first FLT3, FLT2, FLT1 are always displayed.
- When fault recording is indicated (FLT1 etc.), the LEDs flash in compliance with the stored trip information, i.e. those LEDs which showed a continuous light when the fault occurred are now blinking to indicate that it is not a current fault. LEDs which were blinking during trip conditions, (element had picked up) just briefly flash.
- If the relay is still in trip condition and not yet reset (TRIP is still displayed), no measuring values can be shown.
- To delete the trip memory, the push button combination <SELECT/RESET> and <-> has to be pressed for about 3 s. The display shows 'wait'.

## Recorded fault values :

Value displayed	Relevant LED
Phase currents L1, L2, L3, in I/In	L1, L2, L3
Earth current $I_E$ in I/I <sub>n</sub>	E
C.B. switching time in s 1)	C.B.
Expired tripping time of I> in % of t <sub>&gt;</sub>	I>
Expired tripping time of I <sub>E&gt;</sub> in % of t <sub>I<sub>E&gt;</sub></sub> <sup>2)</sup>	I <sub>E&gt;</sub>
<b>Time stamp</b>	
Date : Y = 99	🕒
M = 04	🕒
D = 20	🕒
time : h = 11	🕒
m = 59	🕒
s = 13	🕒

Table 5.7 : Recorded fault values

- 1) C.B. switching time : Time between energizing of the trip output relay and switching of the C.B. (current < 1 % I<sub>N</sub>).
- 2) Expired tripping time : Time between pickup and release of the low set element. This value is only displayed for I> and I<sub>E></sub>.

### 5.10 Reset

Unit MARIK3 has the following three possibilities to reset the relay:

#### Manual Reset

- Pressing the push button <SELECT/RESET> for some time (about 3 s)

#### Electrical Reset

- Through applying auxiliary voltage to C8/D8

#### Software Reset

- The software reset has the same effect as the <SELECT/RESET> push button (see also communication protocol of RS485 interface).

The display can only be reset when the pickup is not present anymore (otherwise "TRIP" remains in display). During resetting of the display the parameters are not affected.

#### 5.10.1 Erasure of fault storage

The fault storage is erased by pressing the key combination <SELECT/RESET> and <-> for about 3 s. At the display "Wait" appears.

## 6. Relay testing and commissioning

The test instructions following below help to verify the protection relay performance before or during commissioning of the protection system. To avoid a relay damage and to ensure a correct relay operation, be sure that:

- The auxiliary power supply rating corresponds to the auxiliary voltage on site,
- the rated current of the relay corresponds to the plant data on site,
- the current transformer circuits and voltage transformer circuits are connected to the relay correctly,
- all signal circuits and output relay circuits are connected correctly.

### 6.1 Power-On

#### NOTE!

Prior to switch on the auxiliary power supply, be sure that the auxiliary supply voltage corresponds to the rated data on the type plate.

Switch on the auxiliary power supply to the relay and check that the message "CSE" appears on the display and the self supervision alarm relay (watchdog) is energized (Contact terminals D7 and E7 closed).

### 6.2 Testing the output relays and LEDs

#### NOTE!

Prior to commencing this test, interrupt the trip circuit to the circuit breaker if tripping is not desired. By pressing the push button <TRIP> once, the display shows the first part of the software version of the relay (e.g. „DO1-“). By pressing the push button <TRIP> twice, the display shows the second part of the software version of the relay (e.g. „1.00“). The software version should be quoted in all correspondence. Pressing the <TRIP> button once more, the display shows "PSW?". Please enter the correct password to proceed with the test. The message "TRI?" will follow. Confirm this message by pressing the push button <TRIP> again. All output relays and LEDs should then be activated and the self supervision alarm relay (watchdog) be deactivated one after another with a time interval of 1 second. In the same manner all LEDs are activated at 0.5 s intervals. Two-coloured LEDs always change from red to green in this process. Thereafter, reset all output relays back to their normal positions by pressing the push button <SELECT/RESET> (about 3 s).

### 6.3 Checking the set values

By repeatedly pressing the push button <SELECT>, all relay set values may be checked. Set value modification can be done with the push button <+><-> and <ENTER>. For detailed information about that, please refer to chapter 5.

## 6.4 Secondary injection test

### 6.4.1 Test equipment

- Voltmeter, Ammeter with class 1 or better,
- auxiliary power supply with the voltage corresponding to the rated data on the type plate,
- single-phase current supply unit (adjustable from 0 to  $\geq 4 \times I_N$ ),
- timer to measure the operating time (Accuracy class  $\leq \pm 10$  ms),
- switching device
- Test leads and tools

### 6.4.2 Example of test circuit for MARIK3 relays

For testing MARIK3 relays only current input signals are required. Figure 6.1 shows a simple example of a single phase test circuit with adjustable current energizing the MARIK3 relay under test.

#### Note!

Care must be taken that the correct functions are assigned to the output relays (refer to 5.7). In this example, relay 1 is assigned to the tripping function and relay 4 to the auto reclosing function.

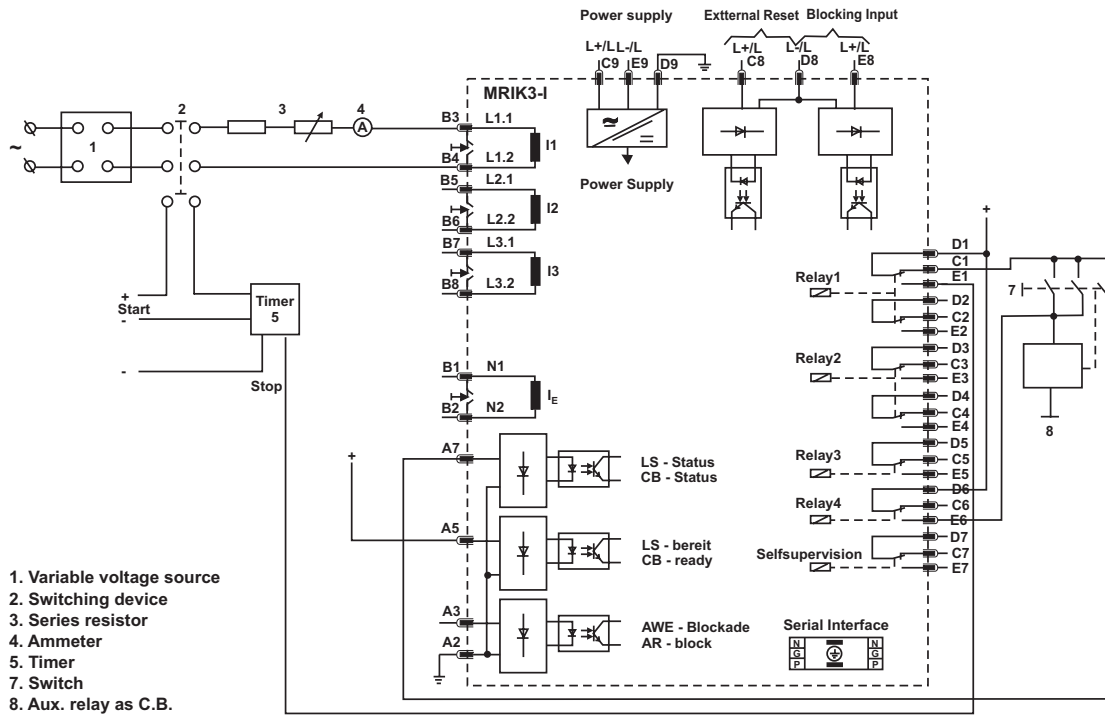

Fig. 6.1 : Test circuit

### 6.4.3 Checking the input circuits and measured values

Inject a current, which is less than the relay pickup current set values, in phase 1 (terminals B3-B4), and check the measured current on the display by pressing the push button <SELECT>. For a relay with rated current  $I_N = 5$  A, for example, a secondary current injection of 1 A should be indicated on the display with about 0.2 ( $0.2 \times I_N$ ). When parameter |prim = „sek“ is set, the indication is  $0.2 \times I_N$  and at „5“ the indication is 1.00 [A]. The current can be also injected into the other current input circuits (Phase 2: terminals B5-B6, Phase 3: terminals B7-B8 and the earth current input). Compare the displayed current value with the reading of the ammeter. The deviation must not exceed 3% of the measuring value or 1%  $I_N$ . By using an RMS-metering instrument, a greater deviation may be observed if the test current contains harmonics. Because the MARIK3 relay measures only the fundamental component of the input signals, the harmonics will be rejected by the internal DFFT-digital filter. Whereas the RMS-metering instrument measures the RMS-value of the input signals.

### 6.4.4 Checking the operating and resetting values of the relay

Inject a current which is less than the relay set values in phase 1 of the relay MARIK3 and gradually increase the current until the relay starts, i.e. at the moment when the LED I> and L1 light up or the alarm output relay I> is activated. Read the operating current indicated by the ammeter. The deviation (MARIK3) must not exceed 3% of the set operating value or 1%  $I_N$ .

Furthermore, gradually decrease the current until the relay resets, i.e. the alarm output relay I> is disengaged. Check that the resetting current is smaller than 0.97 times the operating current.

Repeat the test on phase 2, phase 3 and earth current input circuits in the same manner. (Accuracy of earth current measuring  $\pm 3\%$  of measuring value).

### 6.4.5 Checking the relay operating time

“For this test the AR function should be deactivated. The number of automatic reclosing attempts “SHOT” should be set to “EXIT”.

To check the relay operating time, a timer must be connected to the trip output relay contact. The timer should be started simultaneously with the current injection in the current input circuit and stopped by the trip relay contact. Set the current to a value corresponding to twice the operating value and inject the current instantaneously. The operating time measured by the timer should have a deviation of less than 3% of the set value or ±10 ms (DEFT). Accuracy for inverse time characteristics refer to IEC 255-3.

Repeat the test on the other phases or with the inverse time characteristics in the similar manner.

In case of inverse time characteristics the injected current should be selected according to the characteristic curve, e.g. two times  $I_s$ . The tripping time may be read from the characteristic curve diagram or calculated with the equations given under “technical data”.

Please observe that during the secondary injection test the test current must be very stable, not deviating more than 1%. Otherwise the test results may be wrong.

### 6.4.6 Checking the high set element of the relay

Set a current above the set operating value of  $I>>$ . If required an alarm relay can be tripped if in this moment if it is assigned to this function. Check the tripping time of the high set element according to chapter 6.4.5.

Check the accuracy of the operating current setting by gradually increasing the injected current until the  $I>>$  element picks up. Read the current value from the ammeter and compare it with the desired setting.

Repeat the entire test on other phases and earth current input circuits in the same manner.

#### Note !

Where test currents  $>4 \times I_N$  are used, the thermal withstand capability of the current paths has to be considered (see technical data, chapter 7.1).

### 6.4.7 Checking the auto reclosing function

The auto reclosing function can only be tested by means of an auxiliary relay simulating the C.B. and a push button for manual start. In order to simplify testing, the significant settings of the devices and the value of the test current are provided as follows:

$I>$	= $0.8 \times I_N$
$I> + \text{CHAR}$	= DEFT
$tI>$	= 2 s
$I>>$	= $1.2 \times I_N$
$tI>>$	= 0.5 s
SHOT	= 1
$tF$	= 1.5

$tD1$	= 5 s
$tD2$	= 10 s
$tCI$	= 0.2 s
$tR$	= 10 s
$tF + I>, I>> (IE>, IE>>)$	= 1ST
CB ( $tCBFP$ )	= 2 s (EXIT)
$fN$	= 50 Hz or 60 Hz

Relay assignment: refer to default settings

AR-assignment:

$I>$	= YES
$I>>$	= YES

The test circuit must be set up in accordance with Figure 6.1. First the push button is pressed. The auxiliary relay picks up and the LED CB lights up. With the settings of the devices as shown above, a test current of  $1.5 \times I_N$  should be injected on phase L1. When the pickup value is exceeded, tripping takes place at once and the LEDs  $I>>$  and L1 light up red.

The auxiliary relay releases again. The device changes into the “Starting” status. This is signalled by the LED AR. Now the dead time is running and the LED  $tD1$  lights up green. After expiration of the dead time the LED  $tCI$  briefly lights up and the auxiliary relay trips again. The display shows “CLOS”.

The LED AR is alight furthermore, the  $O \rightarrow I$  lights up green and the LED  $tR$  lights up red. The LED  $tR$  signals that the reclaim time is running. Once it has expired, all LEDs extinguish except for the LED CB, and the display shows “CSE” again. This completes a successful AR simulation.

#### Note:

After the relay has tripped, the test current should be switched off as quickly as possible. Otherwise, there is the danger that the switch failure protection device CBFP picks up. If switching off quickly is impossible,  $tCBFP$  must be set to “EXIT”.

### 6.4.8 Checking the circuit breaker position (A2/A7 and A2/A5)

The aux. voltage has to be applied at terminals (A2/A7). LED  $t_r$  (reclaim time) and the LED CB light up. After the delay time has elapsed, LED  $t_r$  extinguishes and LED AR lights up. This signals that the relay is ready for AR function. Input A2-A5 (C.B. ready) must be „ON“. Without voltage signal at terminals A2/A5 LED CB flashes and the display shows „CB??“.

### 6.4.9 Checking the AR-blocking input (A2/A3)

Connect auxiliary voltage to terminals A2/A3. The display shows “BLOC”.

If the signal at terminals A2/A3 is cancelled, the LED extinguishes and the display shows “CSE” again.

### 6.4.10 Checking the external blocking and reset functions

By means of the external blocking input, it is possible to block all protective functions. To give an example, the blocking function of the phase current high set element is described.

This can be tested by first setting the parameter for the phase current high set element to „BLOC“ and then connecting the auxiliary voltage to terminals E8/D8. The phase current low set element  $I_{>}$  should be set to EXIT for this test. Inject a test current which could cause a high set ( $I_{>}$ ) tripping. Observe that there is no trip of any assigned output relay of the high set or low set element.

Remove the auxiliary supply voltage from the blocking input. Inject a test current to trip the relay (message „TRIP“ on the display). Interrupt the test current and apply auxiliary supply voltage to the external reset input of the relay (terminals C8/D8). The display and LED indications should be reset immediately.

### 6.4.11 Testing the external blocking with Block/Trip function

In order to simplify things, the short-circuit stage is to be tested here as described in Chapter 6.4.10.

For this purpose, the parameter for the Block/Trip function must be set to „TR\_B“ (first value in the blocking menu of the protection functions Chapter 5.7.1). The appertaining Block/Trip time should be longer than the set tripping time  $t_{l>>}$  (see chapter 5.4.19). Here, too, a current is impressed which should make the shortcircuit stage trip. After the Block/Trip time has expired, tripping will take place. Tripping takes place when:

- the blocking input has been set
- a tripping stage has been excited
- the appertaining tripping time has expired
- the Block/trip time has expired

If the Block/Trip time is set shorter than the tripping time, tripping will only take place after the tripping time has expired.

### 6.4.12 Test of the CB failure protection

For testing the tripping time a test current of about two times the rated current to be injected. The timer is started upon tripping of the relay of a protection function ( $I_{>}$ ,  $I_{>>}$ ,  $I_{E>}$ ,  $I_{E>>}$ ) and stopped as soon as the relay for the CB failure protection has picked up. Message „CBFP“ is displayed. The tripping time ascertained by the timer should not deviate more than 1% or, at short trip delay, less than  $\pm 10$  ms from the set tripping time.

Alternatively, the timer can be started when the aux. voltage and the test current are injected simultaneously. The timer stops when the corresponding output relay for circuit breaker failure protection trips.

In this case the previously measured tripping delay has to be subtracted from the total tripping time measured.

## 6.5 Primary injection test

Generally, a primary injection test could be carried out in the similar manner as the secondary injection test described above. With the difference that the protected power system should be, in this case, connected to the installed relays under test „on line“, and the test currents and voltages should be injected to the relay through the current and voltage transformers with the primary side energized. Since the cost and potential hazards are very high for such a test, primary injection tests are usually limited to very important protective relays in the power system.

Because of its powerful combined indicating and measuring functions, the MARIK3 relay may be tested in the manner of a primary injection test without extra expenditure and time consumption.

In actual service, for example, the measured current values on the MARIK3 relay display may be compared phase by phase with the current indications of the ammeter of the switchboard to verify that the relay works and measures correctly:

- Close the circuit breaker manually and check that the LED  $t_r$  (Reclaim time) and CB light up. After the preset delay time, the LED  $t_r$  is extinguished to indicate that the relay is ready for auto reclosing.
- Open the circuit breaker manually and check that the LED CB is extinguished immediately to indicate that the circuit breaker is not ready for auto-reclosing.

## 6.6 Maintenance

Maintenance testing is generally done on site at regular intervals. These intervals vary among users depending on many factors: e.g. the type of protective relays employed; the importance of the primary equipment being protected; the user's past experience with the relay, etc.

For electromechanical or static relays, maintenance testing will be performed at least once a year according to the experiences. For digital relays like MARIK3, this interval can be substantially longer. This is because:

- The MARIK3 relays are equipped with very wide selfsupervision functions, so that many faults in the relay can be detected and signalized during service. Important: The self-supervision output relay must be connected to a central alarm panel!
- The combined measuring functions of MARIK3 relays enable supervision the relay functions during service.
- The combined TRIP test function of the MARIK3 relay allows to test the relay output circuits.

A testing interval of two years for maintenance will, therefore, be recommended.

During a maintenance test, the relay functions including the operating values and relay tripping characteristics as well as the operating times should be tested.

## 7 Technical data

For additional common data of all MR-relays please refer to manual "MR - Digital Multifunctional relays".

### 7.1 Measuring input circuits

Rated data	:	Nominal current $I_N$	1 A or 5 A
		Nominal frequency $f_N$	50 Hz; 60 Hz adjustable
Power consumption in current circuit	:	at $I_N = 1$ A	0.2 VA
		at $I_N = 5$ A	0.1 VA
Thermal withstand capability in current circuit	:	dynamic current withstand (half-wave)	250 x $I_N$
		for 1 s	100 x $I_N$
		for 10 s	30 x $I_N$
		continuously	4 x $I_N$

### 7.2 Common data

Dropout to pickup ratio	:	>97%
Dropout to pickup ratio for phase current in range $0.2 \times I_N$ to $0.5 \times I_N$	:	= 100 %
Returning time	:	30 ms
Time lag error class index E	:	$\pm 10$ ms
Minimum operating time	:	30 ms
Transient overreach at instantaneous operation	:	$\leq 5\%$

#### Influences on the current measurement:

Auxiliary voltage	:	in the range of $0.8 < U_H / U_{HN} < 1.2$ no additional influences can be measured
Frequency	:	in the range of $0.9 < f/f_N < 1.1$ ; $< 0.2\%$ / Hz
Harmonics	:	up to 20% of the third harmonic; $< 0.08\%$ per percent of the third harmonic up to 20% of the fifth harmonic; $< 0.07\%$ per percent of the fifth harmonic
Influences on delay times	:	no additional influences can be measured
GL-Approbation	:	98775-96
Bureau Veritas Approbation	:	2 650 6807 A00H

### 7.3 Setting ranges and steps

#### 7.3.1 Time overcurrent protection

	Setting range	Step	Tolerance
$I_{prim}$	(SEK) 0.002...50 kA	0.001; 0.002; 0.005; 0.01; 0.02; 0.05; 0.1; 0.2	
$I_{>}$	$0.2...4.0 \times I_N$ (EXIT)	$0.01, 0.02, 0.05; 0.1 \times I_N$	$\pm 3\%$ from set value or min. $\pm 1\% I_N$
$t_{l>}$	0.03 – 260 s (EXIT) (definite time)	0.01; 0.02; 0.1; 0.2; 0.5; 1.0; 2.0; 5.0 10.0; 20.0 s	$\pm 3\%$ or $\pm 10$ ms
	0.05 - 10 (EXIT) (inverse time)	0.01; 0.02; 0.05; 0.1; 0.2	$\pm 5\%$ for NINV and VINV $\pm 7.5\%$ for NINV and EINV
$I_{>>}$	$0.5...40 \times I_N$ (EXIT)	0.02; 0.05; 0.1; 0.2; 0.5; $1.0 \times I_N$	$\pm 3\%$ from set value or min. $\pm 1\% I_N$
$t_{I>>}$	0.03...10 s (EXIT)	0.01 s; 0.02 s; 0.05 s; 0.1 s; 0.2 s	$\pm 3\%$ or $\pm 10$ ms

Table 7.1: Setting ranges for time overcurrent protection

### 7.3.2 Earth fault protection

	Setting range	Step	Tolerance
$I_{prim}$	(SEK) 0.002...50 kA	0.001; 0.002; 0.005; 0.01; 0.02; 0.05; 0.1; 0.2	
$I_E >$	0.01...2.0 x $I_N$ (EXIT)	0.001; 0.002; 0.005; 0.01; 0.02; 0.05 x $I_N$	±5% from set value or ±0.3% $I_N$
$t_{IE} >$	0.04 – 260 s (EXIT) (definite time) 0.06 – 10 (EXIT) (inverse time)	0.01; 0.02; 0.05; 0.1; 0.2; 0.5; 1.0; 2.0; 5.0; 10.0; 20.0 s 0.01; 0.02; 0.05; 0.1; 0.2	±3% or ±15 ms  ±5% for NINV and VINV ±7.5% for NINV and EINV
$I_E >>$	0.01...15 x $I_N$ (EXIT)	0.01; 0.02; 0.05; 0.1; 0.2; 0.5 x $I_N$	±5% from set value or min. ±1% $I_N$
$t_{IE} >>$	0.04...10 s (EXIT)	0.01 s; 0.02 s; 0.05 s; 0.1 s; 0.2 s	±3% or ±15 ms

Table 7.2: Setting ranges for earth fault protection

### 7.3.3 Inverse time overcurrent protection

According to IEC 255-4 or BS 142

Normal inverse (Type A)  $t = \frac{0.14}{\left(\frac{I}{I_s}\right)^{0.02} - 1} t_i > [s]$

Very inverse (Type B)  $t = \frac{13.5}{\left(\frac{I}{I_s}\right) - 1} t_i > [s]$

Extremely inverse (Type C)  $t = \frac{80}{\left(\frac{I}{I_s}\right)^2 - 1} t_i > [s]$

Long time inverse  $t = \frac{120}{\left(\frac{I}{I_s}\right) - 1} t_i > [s]$

RI-inverse  $t = \frac{1}{0.236 - \frac{0.339}{\left(\frac{I}{I_s}\right)}} t_i > [s]$

\* RXIDG - characteristics  $t = 5.8 - 1.3 * \left[ \ln \times \left(\frac{I}{I_s}\right) \right] \times t_i > [s]$

Where :

- $t$  = Tripping time
- $t_i >$  = Time multiplier
- $I$  = Fault current
- $I_s$  = Starting current
- $I_N$  = Natural logarithm

\* only for earth current

### 7.3.4 Inverse time characteristics

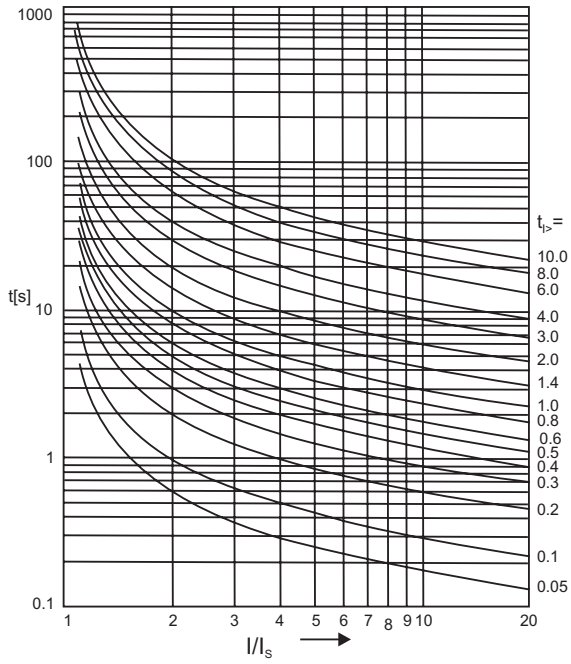

Fig. 7.1 : Normal Inverse

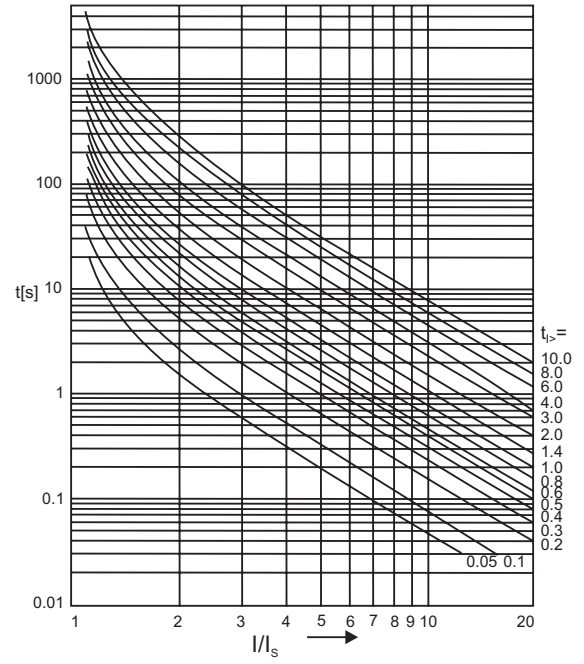

Fig. 7.3 : Extremely Inverse

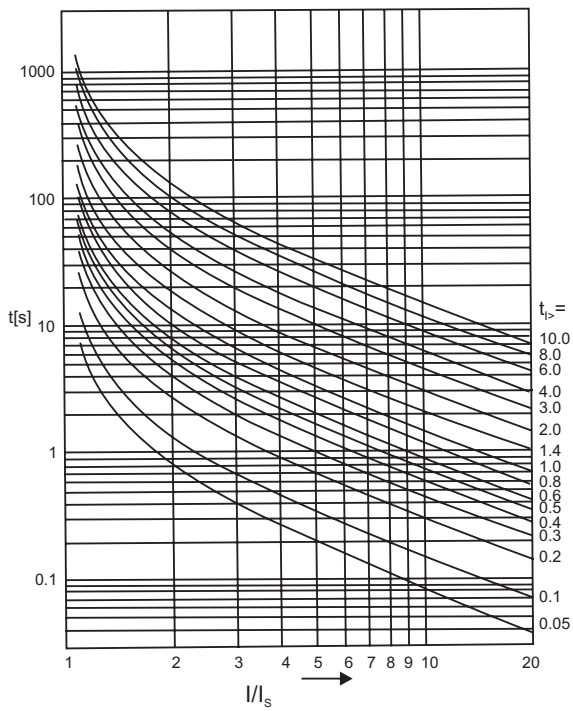

Fig. 7.2 : Very Inverse

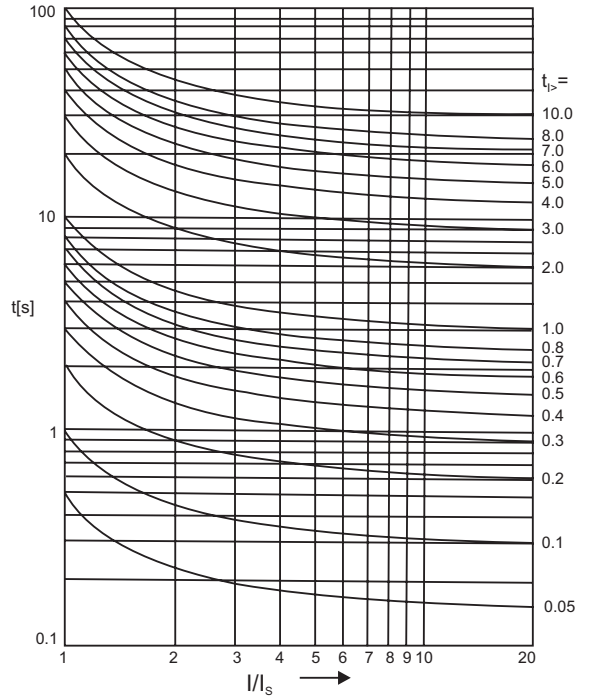

Fig. 7.4 : RI-Inverse

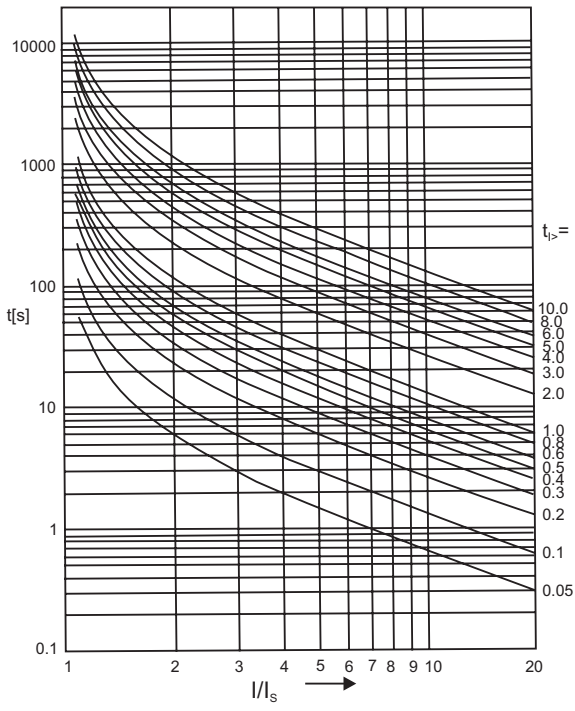

Fig. 7.5 : Long Time Inverse

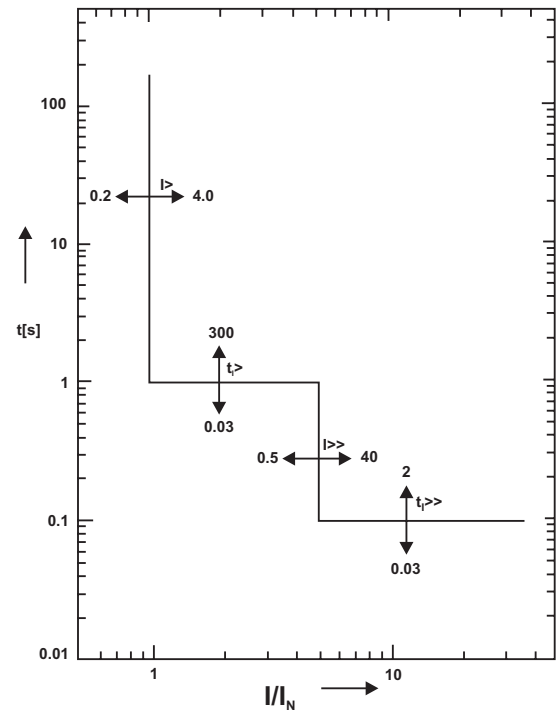

Fig. 7.7 : Definite time overcurrent Inverse

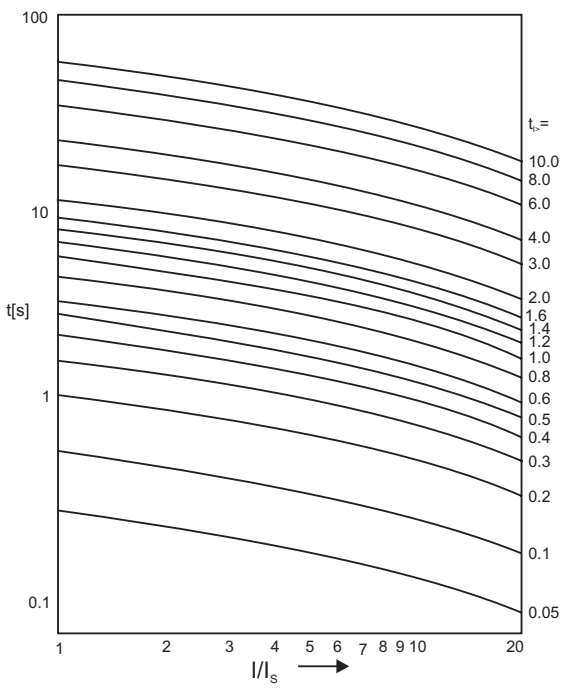

Fig. 7.6 : RXIDG-characteristic

## 7.4 Parameter

### AR Parameters

	Setting range	Step	Tolerance
SHOT	1..4 (EXIT)	1	
$t_F$	0,1...20 s	0.01; 0.02; 0.05; 0.1; 0.2; 0.5; 1 s	±3% bzw. 10 ms
$t_{D1}$	0,1...20 s	0.01; 0.02; 0.05; 0.1; 0.2; 0.5; 1 s	
$t_{D2}$	0,1...100 s	0.01; 0.02; 0.05; 0.1; 0.2; 0.5; 1; 2; 5 s	
$t_{D3}$	0,1...100 s	0.01; 0.02; 0.05; 0.1; 0.2; 0.5; 1; 2; 5 s	
$t_{D4}$	0,1...100 s	0.01; 0.02; 0.05; 0.1; 0.2; 0.5; 1; 2; 5 s	
$t_{Cl}$	0,05...2 s	0.01; 0.02; 0.05 s	
$t_R$	1,0...300 s	0.1; 0.2; 0.5; 1; 2; 5; 10; 20 s	
$t_{Factive}$	1ST/ALL		

Table 7.3: AR parameters

### Fixed parameters

Fixed parameter	Value	Tolerance	Remarks
Tripping time	200 ms	< 10 ms	This time starts with the protection tripping command (before the first AR) and is interrupted by the C.B. OFF-signal. When this time has expired, a C.B. defect is present.
Energy wait time	200 ms	< 10 ms	During this time the C.B. stand-by is supervised before reclosing. It can be deactivated by applying the aux. voltage to connection A5.

Table 7.4: Fixed parameters

### Block/Trip – time

	Setting range	Step	Tolerance
$T_{BLOCK/TRIPP}$	0.1...2 s (EXIT)	0.01 s; 0.02 s; 0.05 s	±3 % or 15 ms

Table 7.5: Block/Trip - time

### Circuit breaker failure protection

	Setting range	Step	Tolerance
$t_{CBFP}$	0.1...2 s (EXIT)	0.01 s; 0.02 s; 0.05 s	±3 % or 15 ms

Table 7.6: C.B. failure protection

### Interface parameter

Function	Parameter	Modbus-Protocol	RS485 Open Data Protocol
RS	Slave-Address	1 - 32	1 - 32
RS	Baud-Rate*	1200, 2400, 4800, 9600	9600 (fixed)
RS	Parity*	even, odd, no	"even Parity" (fixed)

Table 7.7: Intereface parameters

\*only Modbus Protocol

Parameters for the fault recorder

Function	Parameter	Adjustment example
FR	Number of recordings	(1)* 2 x 8 s; (3)* 4 x 4 s; (7)* 8 x 2 s (with 50 Hz) (1)* 2 x 6.66 s, (3)* 4 x 3.33 s, (7)* 8 x 1.66 s (60 Hz)
FR	Saving of the recording at the occurrence	P_UP; TRIP; A_PI; TEST
FR	Pre-trigger-time	0.05 s – 8.00 s

Table 7.8: Parameters for the fault recorder

\* is written over when a new trigger signal arrives

### 7.5 Design standard

VDE 0435, Part 303; IEC255-4

VDEW ring book - Protection technique

Requirements on the C.B.s: DIN VDE 0670

### 8 Order form

Time overcurrent relay with AR MARIK3-						
3-phase measuring I>, I>>		<b>I</b>				
rated current	1A		<b>1</b>			
	5A		<b>5</b>			
Earth current measuring				<b>E</b>		
rated current in earth path	1A				<b>1</b>	
	5A				<b>5</b>	
Housing (12TE)	9"-rack					<b>A</b>
	Flush mounting					<b>D</b>
RS485	Alternatively with Modbus Protocol					<b>-M</b>

Technical data subject to change without notice!

## Setting list MRIK3

Project: \_\_\_\_\_

CSE-Job. No. : \_\_\_\_\_

Function group: = \_\_\_\_\_ Location: + \_\_\_\_\_

Relay code: \_\_\_\_\_

Relay functions: \_\_\_\_\_

Password: \_\_\_\_\_

Date: \_\_\_\_\_

All settings must be checked at site and should the occasion arise, adjusted to the object/item to be protected.

### Adjustment of the parameters

#### System parameters

Function		Unit	I	IE	Default setting	Actual setting
					Set 1/Set 2	Set 1/Set 2
$I_{prim} L1, L2, L3$	Display of measuring values as primary quantities	s	X	X	SEK	
$I_{primE}$	Display of measuring value as primary quantities	s		X	SEK	
50/60 Hz	Rated frequency	Hz	X	X	50 Hz	
LED Flash	Display of the activation storage		X	X	FLSH	
P2	Parameter switch/external triggering of the fault recorder				Set 1	

#### Protection parameter

Function		Unit	I	IE	Default setting	Actual setting	
					Set 1/Set 2	Set 1	Set 2
$I>$	Overcurrent pickup value	$I_N$	X	X	0.2		
$I>CHAR$	Tripping characteristic overcurrent		X	X	DEFT		
$t_{I>}$	Overcurrent tripping delay	s	X	X	0.03		
$I>/t_{RST}$	Reset-mode		X	X	0 s		
$I>>$	Pickup value for high set element	$I_N$	X	X	0.5		
$tI>>$	Tripping delay for high set element	s	X	X	0.03		
$IE>$	Pickup value for earth fault overcurrent	$I_N$		X	0.01		
WARN/TRIP	Warning/Tripping			X	TRIP		
$I_E CHAR$	Tripping characteristic earth fault			X	DEFT		
$tIE>$	Tripping delay for earth fault overcurrent	s		X	0.04		
$IE>/t_{RST}$	Reset-mode			X	0 s		
$IE>>$	Pickup value earth fault high set element	$I_N$		X	0.01		
$tIE>>$	Tripping delay for earth fault high set element	s		X	0.04		
SHOT	Number of Shots		X	X	4		
$t_F$	Fault time $t_F$	s	X	X	0.1		
$t_{D1}$	Dead time $t_{D1}$	s	X	X	1.0		
$t_{D2}$	Dead time $t_{D2}$	s	X	X	2.0		
$t_{D3}$	Dead time $t_{D3}$	s	X	X	2.0		
$t_{D4}$	Dead time $t_{D4}$	s	X	X	2.0		
$t_{Cl}$	Close impulse time $t_{Cl}$	s	X	X	0.5		
$t_R$	Reclaim time $t_R$	s	X	X	10.0		
$t_{Factive}$	Fault time activation		X	X	1ST		
Block/Trip	Block/trip - time	s	X	X	EXIT		
$t_{CBFP}$	Max.Circuit breaker tripping time	s	X	X	EXIT		
50/60 Hz	Rated frequency	Hz	X	X	50		
RS	Slave address		X	X	1		
RS*	Baud-Rate*		X	X	9600		
RS*	Parity-Check*		X	X	even		

<sup>1)</sup> only Modbus Protocol

### Fault recorder

Function		Unit	Default settings	Actual settings
FR	Number of recordings		4	
FR	Saving of the recording at the occurrence		TRIP	
FR	Time prior to trigger impulse	s	0.05	
⊕	Year setting	year	Y=00	
⊕	Month setting	month	M=00	
⊕	Day setting	day	D=00	
⊕	Setting of the hour	hour	h=00	
⊕	Setting of the minute	minute	m=00	
⊕	Setting of the setting	second	s=00	

### Assignment of the blocking function

Parameter switch	Default setting		Actual setting	
	Set 1	Set 2	Set 1	Set 2
Blocking the protection function PR_B	PR_B	PR_B		
Blocking the trip step TR_B				

Function	Default setting				Actual setting			
	Blocking		No blocking		Blocking		No blocking	
	Set 1	Set 2	Set 1	Set 2	Set 1	Set 2	Set 1	Set 2
I>			X	X				
I>>	X	X						
I <sub>E&gt;</sub>			X	X				
I <sub>E&gt;&gt;</sub>			X	X				
t <sub>CBFP</sub>			X	X				

### Assignment of the output relays

Relay function	Output relay				Display indication	corresponding LED
	1	2	3	4		
I> Alarm		X			_ 2 _ _	I>
I> Tripping	X				1 _ _ _	tI>
I>> Alarm		X			_ 2 _ _	I>>
I>> Tripping	X				1 _ _ _	tI>>
I>> <sub>FAST TRIP</sub> Tripping	X				1 _ _ _	I>> + CB
I <sub>E&gt;</sub> Alarm		X			_ 2 _ _	I <sub>E&gt;</sub>
I <sub>E&gt;</sub> Tripping	X				1 _ _ _	tI <sub>E&gt;</sub>
I <sub>E&gt;&gt;</sub> Alarm		X			_ 2 _ _	I <sub>E&gt;&gt;</sub>
I <sub>E&gt;&gt;</sub> Tripping	X				1 _ _ _	tI <sub>E&gt;&gt;</sub>
CBFP Tripping					_ _ _ _	CB
AR Switch on				X	_ _ _ 4	AR + t <sub>CL</sub>
AR Unsuccessful			X		_ _ 3 _	AR + O→I rot

### Assignment of AR functions

Function	Default setting		Actual setting	
	Set 1	Set 2	Set 1	Set 2
Parameter switch				
Trip after the 1st AR				
I>	TIME	TIME		
I>>	TIME	TIME		
IE>	TIME	TIME		
IE>>	TIME	TIME		
Activation of the 1 <sup>st</sup> AR per				
I>	NO	NO		
I>>	YES	YES		
IE>	NO	NO		
IE>>	NO	NO		
Trip after the 1 <sup>st</sup> AR				
I>	TIME	TIME		
I>>	TIME	TIME		
IE>	TIME	TIME		
IE>>	TIME	TIME		
Activation of the 2 <sup>nd</sup> AR per				
I>	NO	NO		
I>>	YES	YES		
IE>	NO	NO		
IE>>	NO	NO		
Trip after the 2 <sup>nd</sup> AR				
I>	TIME	TIME		
I>>	TIME	TIME		
IE>	TIME	TIME		
IE>>	TIME	TIME		
Activation of the 3 <sup>rd</sup> AR per				
I>	NO	NO		
I>>	YES	YES		
IE>	NO	NO		
IE>>	NO	NO		
Trip after the 3 <sup>rd</sup> AR				
I>	TIME	TIME		
I>>	TIME	TIME		
IE>	TIME	TIME		
IE>>	TIME	TIME		
Activation of the 4 <sup>th</sup> AR per				
I>	NO	NO		
I>>	YES	YES		
IE>	NO	NO		
IE>>	NO	NO		
Trip after 4 <sup>th</sup> AR				
I>	TIME	TIME		
I>>	TIME	TIME		
IE>	TIME	TIME		
IE>>	TIME	TIME		

**Setting of code jumpers**

Code jumper	J1		J2		J3	
	Default setting	Actual setting	Default setting	Actual setting	Default setting	Actual setting
Plugged						
Not plugged	X		no function		no function	

Code jumper	Low / High-range for Reset input		Low / High-range for blockage input	
	Default setting	Actual setting	Default setting	Actual setting
Low = plugged	X		X	
High = not plugged				

Code jumper	Low / High-range for Reset input		Low / High-range for the CB-OK-input		Low / High-range for the CB-On-input	
	Default setting	Actual setting	Default setting	Actual settings	Default setting	Actual setting
Low = plugged	X		X		X	
High = not plugged						

This manual is valid for relay software version from

Software versions number : D01-2.13

Modbus versions number : D5-1.23

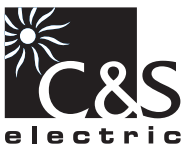

## **C&S Electric Limited**

**(Protection & Control Division)**

44, Okhla Industrial Estate, New Delhi -110 020 (INDIA)

Phone : +91 11- 66602414, 30883745/54/64 Fax: +91 11- 66602413

E-mail: [cspc@cselectric.co.in](mailto:cspc@cselectric.co.in) Web : [www.cselectric.co.in](http://www.cselectric.co.in)

### **Marketing Offices :**

**AHMEDABAD:** +91 79 30074534/35/36 FAX : +91 79 30074519 **BANGALORE:** +91 80 25586147, 25594939 FAX : +91 25584839  
**BHUBANESWAR :** +91 674 2507265 FAX : +91 674 2507265 **CHANDIGARH :** +91 172 272613, 3062624 FAX : +91 172 2726153  
**CHENNAI :** +91 44 39180531/32/33/34 FAX:+91 44 39180514 **DELHI :** +91 11 30838822-25 Fax:+91 11 30838826 **HYDERABAD :** +91 40 27813003  
FAX : +91 40 27812987 **KOLKATA :** +91 33 22275850/51 FAX : +91 33 22275849 **MUMBAI :** +91 22 24114727/28 FAX : +91 22 24126631  
**NAGPUR :** +91 712 5616651 FAX : +91 712 5616651 **PUNE :** +91 20 30283244/45 FAX : +91 20 30283245 **RAIPUR :** +91 771 320852433/34